

LOTUS SERIES | SENSORY AND SAFE

Fōm CHAIR

Product No. FK020

Our Fōm Chair is built for comfort and flexibility. Full-foam construction makes this a lightweight and adaptable piece for any educational space. This classic design combines with pieces like our Fōm Desk to create safe environments for sensory learners. Use it individually or combine it with other seating to encourage collaborative learning.



DETAILS

CONSTRUCTION

- Solid foam construction
- Reinforced seams and stitching
- Fully zippered (no wood base)
- Made in USA
- Backed with a lifetime warranty

MODIFICATION

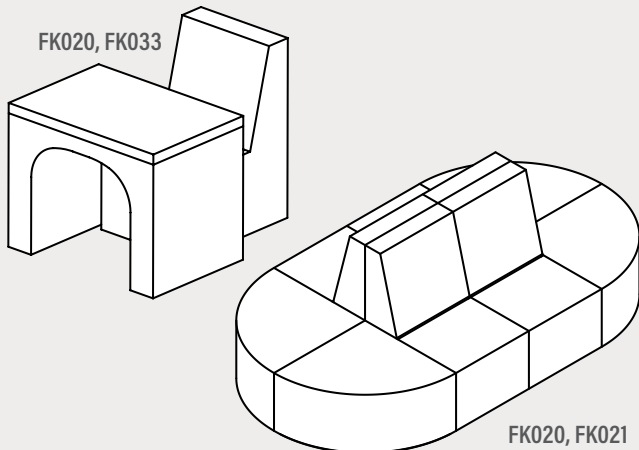

- Textile & placement
- Colored stitching and zipper
- Embroidery

QUICK COMBOS



HOW TO SPECIFY FK020

STEP 1: HEIGHT

DIMENSION (L x W x H)	SEAT HEIGHT	DIMENSION (L x W x H)	SEAT HEIGHT	DIMENSION (L x W x H)	SEAT HEIGHT
 16" x 18" x 23.25"	10"	 21" x 26.5" x 35"	16"	 24" x 30" x 39.5"	18"

STEP 2: FULLY ZIPPERED

FULLY ZIPPERED



Fully Zippered (Z)

**Reference the product breakdown on back for availability.*

STEP 3: GRADE AND TEXTILE

GRADES & SWATCHES



[CLICK TO VIEW »](#)

FABRIC DIRECTION & COLOR GUIDE



[CLICK TO VIEW »](#)

COLOR GUIDE

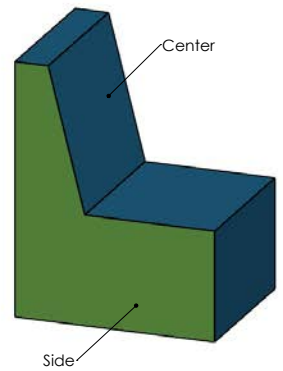

**Thread will default to match the seat textile.*

STEP 4: ACCESSORIES (OPTIONAL)

EMBROIDERY

- Personalize your furniture with embroidery!
- We can embroider logos up to 12" x 15".

EMBROIDERY SPECS

[CLICK TO VIEW »](#)



CAL TB-133

- Optional flame retardant add on.

**Reference the product breakdown on back for availability.*

STEP 5: CONFIGURE PART NUMBER

FILL IN YOUR PART NUMBER

F	K	0	2	0	-	2	1	x	2	6	.	5	x	3	5	-	Z		
FAMILY						STEP 1										STEP 2			
L						W					H					ZIP			

EXAMPLE PART NUMBER

F	K	0	2	0	-	2	1	x	2	6	.	5	x	3	5	-	Z		
FAMILY						STEP 1										STEP 2			
L						W					H					ZIP			

STEP 6: CONFIGURE DESCRIPTION

FILL IN YOUR DESCRIPTION

1. CENTER

1. Center				
LOCATION	GRADE	MANUFACTURER	PATTERN	COLOR

2. SIDE

2. Side				
LOCATION	GRADE	MANUFACTURER	PATTERN	COLOR

STEP 3

EMBROIDERY*

LOCATION	NAME
----------	------

FLAME RETARDANT*

--

EXAMPLE DESCRIPTION

1. CENTER

1. Center	1	Spradling	Silvertex	Sage
LOCATION	GRADE	MANUFACTURER	PATTERN	COLOR

2. SIDE

2. Side	3	Momentum	Tribeca	Fossil
LOCATION	GRADE	MANUFACTURER	PATTERN	COLOR

EMBROIDERY*

Seat	Rocket Logo
LOCATION	NAME

FLAME RETARDANT*

CAL TB-133

*Optional add-ons. Reference product breakdown for availability.

INCLUDE ON PURCHASE ORDER

EXAMPLE CONFIGURATION

FK020-21x26.5x35-Z

1. Center: Grade 1, Spradling, Silvertex, Sage | 2. Side: Grade 3, Momentum, Tribeca, Fossil

Embroidery: Seat, Rocket logo | CAL TB-133

PRODUCT BREAKDOWN

FÖM DESK & CHAIR

Description/ Product No.	Dimen./Weight (L x W x H)	FOOT OPTIONS											INTEGRATED POWER OPTIONS						TFL	Emb.				
		Zip Z	Standard		3" Premium		6" Premium				Standard		3" Premium		6" Premium									
			G1	L1	R3	C3	S16	S29	C6	T6	R6	M6	G1	L1	R3	C3	S16	S29			C6	T6	R6	M6
Föm Desk FK033-30x20x21	30" x 20" x 21" 8 lbs.	✓	-	-	-	-	-	-	-	-	-	-	-	-	-	-	-	-	-	-	-	-	-	✓
Föm Chair FK020-16x18x23.25	16" x 18" x 23.25" 8 lbs. (10" Seat Height)	✓	-	-	-	-	-	-	-	-	-	-	-	-	-	-	-	-	-	-	-	-	-	✓
Föm Desk FK033-35x24x29	35" x 24" x 29" 13 lbs.	✓	-	-	-	-	-	-	-	-	-	-	-	-	-	-	-	-	-	-	-	-	-	✓
Föm Chair FK020-21x26.5x35	21" x 26.5" x 35" 9 lbs. (16" Seat Height)	✓	-	-	-	-	-	-	-	-	-	-	-	-	-	-	-	-	-	-	-	-	-	✓
Föm Desk FK033-38x24x31	38" x 24" x 31" 14 lbs.	✓	-	-	-	-	-	-	-	-	-	-	-	-	-	-	-	-	-	-	-	-	-	✓
Föm Chair FK020-24x30x39.5	24" x 30" x 39.5" 10 lbs. (18" Seat Height)	✓	-	-	-	-	-	-	-	-	-	-	-	-	-	-	-	-	-	-	-	-	-	✓

Fömcöre
SERVE. CREATE. INSPIRE.

1770 E. Keating Ave - Muskegon, MI 49442 • Tel: 231.366.4791 • www.fomcore.com

ADDITIONAL
RESOURCES



CLICK TO VIEW »