

NEST SERIES

EAGLE'S NEST

Product No. F586

Our patent pending Nest Series* is where mindfulness and reflection meet. The Eagle's Nest* is the perfect spot for a little alone time. Learners can tuck away in this sound dampening space to find a comfortable and safe space to sit, read and reflect. The solid foam construction allows for light-weight and easy movement.



DETAILS

CONSTRUCTION

- Solid foam construction
- Reinforced seams and stitching
- Fully zippered (no wood base)
- Patented*
- Made in USA
- Backed with a lifetime warranty

MODIFICATION

- Textile and placement
- Colored stitching
- Embroidery

QUICK COMBOS

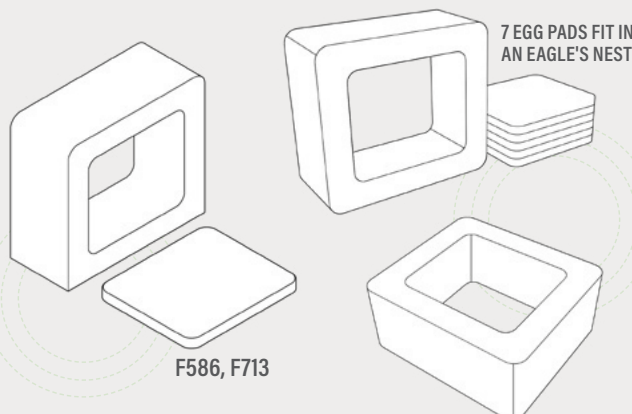

Fōmcore
SERVE. CREATE. INSPIRE.

HOW TO SPECIFY F586

STEP 1: HEIGHT

DIMENSION (L x W)	HEIGHT
57" x 24"	51"

STEP 2: FULLY ZIPPERED

FULLY ZIPPERED



Fully Zippered (Z)

**Reference the product breakdown on back for availability.*

STEP 3: GRADE AND TEXTILE

GRADES & SWATCHES



[CLICK TO VIEW »](#)

FABRIC DIRECTION & COLOR GUIDE



[CLICK TO VIEW »](#)

**Thread will default to match the seat textile.*

COLOR GUIDE

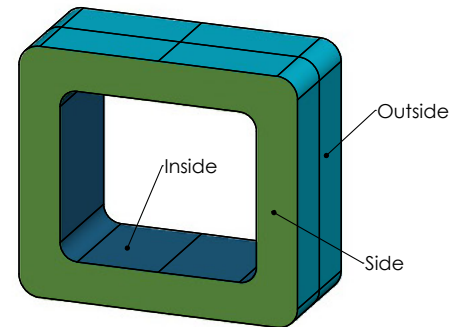

STEP 4: ACCESSORIES (OPTIONAL)

EMBROIDERY

- Personalize your furniture with embroidery!
- We can embroider logos up to 12" x 15".

EMBROIDERY SPECS

[CLICK TO VIEW »](#)



CAL TB-133

- Optional flame retardant add on.

**Reference the product breakdown on back for availability.*

STEP 5: CONFIGURE PART NUMBER

FILL IN YOUR PART NUMBER

F	5	8	6	-	5	7	x	2	4	x	5	1	Z						
FAMILY					L				W				H				ZIP		
STEP 1												STEP 2							

EXAMPLE PART NUMBER

F	5	8	6	-	5	7	x	2	4	x	5	1	Z						
FAMILY					L				W				H				ZIP		

STEP 6: CONFIGURE DESCRIPTION

FILL IN YOUR DESCRIPTION

1. INSIDE

1. Inside					
LOCATION	GRADE	MANUFACTURER	PATTERN	COLOR	

2. SIDES

2. Sides					
LOCATION	GRADE	MANUFACTURER	PATTERN	COLOR	

3. OUTSIDE

3. Outside					
LOCATION	GRADE	MANUFACTURER	PATTERN	COLOR	

EMBROIDERY*

Seam	Rocket Logo
LOCATION	NAME

FLAME RETARDANT*

CAL TB-133

STEP 3

EXAMPLE DESCRIPTION

1. INSIDE

1. inside	1	Spradling	Silvertex	Sage
LOCATION	GRADE	MANUFACTURER	PATTERN	COLOR

2. SIDES

2. Sides	3	Momentum	Tribeca	Fossil
LOCATION	GRADE	MANUFACTURER	PATTERN	COLOR

3. OUTSIDE

3. Outside	3	Momentum	Tribeca	Fossil
LOCATION	GRADE	MANUFACTURER	PATTERN	COLOR

EMBROIDERY*

Seam	Rocket Logo
LOCATION	NAME

FLAME RETARDANT*

CAL TB-133

*Optional add-ons. Reference product breakdown for availability.

INCLUDE ON PURCHASE ORDER

EXAMPLE CONFIGURATION

F586-57x24x51-Z

1. Inside: Grade 1, Spradling, Silvertex, Sage | 2. Sides: Grade 3, Momentum, Tribeca, Fossil
3. Outside: Grade 3, Momentum, Tribeca, Fossil | Embroidery: Seat, Rocket logo | CAL TB-133

PRODUCT BREAKDOWN

EAGLE'S NEST (F586)

Product No.	Dimen./Weight (L x W x H)	FOOT OPTIONS												INTEGRATED POWER OPTION												TFL	Emb.
		Zip Z	Standard G1 L1		3" Premium R3 C3		6" Premium S16 S29 C6 T6 R6 M6				Standard G1 L1		3" Premium R3 C3		6" Premium S16 S29 C6 T6 R6 M6												
F586-57x24x51	57" x 24" x 51" 42 lbs.	✓	-	-	-	-	-	-	-	-	-	-	-	-	-	-	-	-	-	-	-	-	-	✓			



1770 E. Keating Ave - Muskegon, MI 49442 • Tel: 231.366.4791 • www.fomcore.com

ADDITIONAL
RESOURCES



CLICK TO VIEW »