

ARMLSS SERIES

LINEAR REFRESH LOVESEAT

Product No. F140

With its sophisticated look, smooth edges and lightweight structure, mix and match the Linear Fresh Loveseat with multiple pieces of the Refresh Series. The size of the loveseat will dress up any small to medium space. The Refresh Series is great for offices, meeting spaces and spaces in between.



DETAILS

CONSTRUCTION

- Solid foam construction
- MDF baseboard to fit foot options
- Reinforced seams and stitching
- Made in USA
- Backed with a lifetime warranty

MODIFICATION

- Seat height
- Textile and placement
- Leg, caster, and foot options
- Colored stitching and zipper
- Embroidery
- Power

QUICK COMBOS

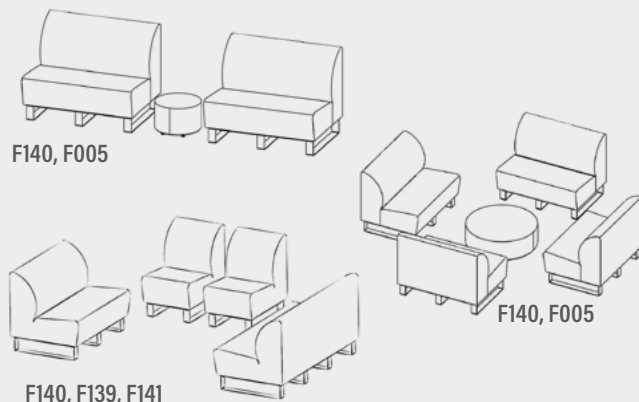

HOW TO SPECIFY F140

STEP 1: SEAT HEIGHT

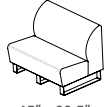
DIMENSION (L x W)	HEIGHT	SEAT HEIGHT
 45" x 32.5"	33"	16"
	35"	18"

STEP 2: FOOT









1" STANDARD FOOT OPTIONS

-  Nylon Glide (G1)
-  Felt Glide (G1)
-  1" Low Profile Leg (L1)
Black

3" PREMIUM FOOT OPTIONS

-  3" Rectangle (R3)
Black
-  3" Rectangle (R3)
Silver
-  3" Caster (C3)

6" PREMIUM FOOT OPTIONS

-  Large Sled Leg (S29)
Silver
-  Large Sled Leg (S29)
Black
-  6" Mod Leg (M6)
-  6" Rectangle (R6)
Black
-  6" Rectangle (R6)
Silver
-  6" Triangle (T6)
Black
-  6" Triangle (T6)
Silver
-  6" Caster (C6)

*Reference the product breakdown on back for availability.

STEP 3: GRADE AND TEXTILE

GRADES & SWATCHES



[CLICK TO VIEW »](#)

FABRIC DIRECTION & COLOR GUIDE



[CLICK TO VIEW »](#)

COLOR GUIDE

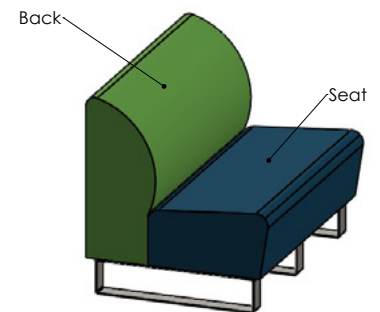

STEP 4: ACCESSORIES (OPTIONAL)

INTEGRATED POWER OPTIONS* (PI, PI+)

-  White
-  Silver

PI = 1 Power Unit
PI+ = 2 Power Units

EMBROIDERY

- Personalize your furniture with embroidery!
- We can embroider logos up to 12" x 15".

EMBROIDERY SPECS

[CLICK TO VIEW »](#)



CAL TB-133

- Optional flame retardant add on.

*Reference the product breakdown on back for availability.

STEP 5: CONFIGURE PART NUMBER

FILL IN YOUR PART NUMBER

F	1	4	0	-	x	x	x	x	-					-					
FAMILY					STEP 1					STEP 2				STEP 4* (OPTIONAL)					
L				W				H				FOOT				POWER			

EXAMPLE PART NUMBER

F	1	4	0	-	4	5	x	3	2	5	x	3	3	-	R	6	-	P	1	
FAMILY					L				W				H				FOOT		POWER	

STEP 6: CONFIGURE DESCRIPTION

FILL IN YOUR DESCRIPTION

1. SEAT

1. Seat					
LOCATION	GRADE	MANUFACTURER	PATTERN	COLOR	

2. SIDE

2. Side					
LOCATION	GRADE	MANUFACTURER	PATTERN	COLOR	

FOOT

NAME/COLOR

POWER*

COLOR	QUANTITY
-------	----------

EMBROIDERY*

LOCATION	NAME
----------	------

STEP 3

EXAMPLE DESCRIPTION

1. SEAT

1. Seat	1	Spradling	Silvertex	Sage
LOCATION	GRADE	MANUFACTURER	PATTERN	COLOR

2. SIDE

2. Side	3	Momentum	Tribeca	Fossil
LOCATION	GRADE	MANUFACTURER	PATTERN	COLOR

FOOT

6" Rectangle Leg - Black	White	1
NAME/COLOR	COLOR	QUANTITY

EMBROIDERY*

Seat	Rocket Logo
LOCATION	NAME

*Optional add-ons. Reference product breakdown for availability.

INCLUDE ON PURCHASE ORDER

EXAMPLE CONFIGURATION

F140-22x33.5x33-R6-P1

1. Seat: Grade 1, Spradling, Silvertex, Sage | 2. Side: Grade 3, Momentum, Tribeca, Fossil

Foot: 6" Rectangle Leg Black | Power: White, Quantity: 1 | Embroidery: Seat, Rocket logo

PRODUCT BREAKDOWN

LINEAR REFRESH LOVESEAT (F140)

Product No.	Dimen./Weight (L x W x H)	Zip Z	FOOT OPTIONS												INTEGRATED POWER OPTION						TFL	Emb.		
			Standard		3" Premium		6" Premium				Standard		3" Premium		6" Premium									
			G1	L1	R3	C3	S16	S29	C6	T6	R6	M6	G1	L1	R3	C3	S16	S29	C6	T6			R6	M6
F140-45x32.5x33	45" x 32.5" x 33" 60 lbs. (16" Seat Height)	-	✓	✓	✓	✓	-	✓	✓	✓	✓	✓	✓	✓	✓	✓	-	-	-	-	-	-	-	✓
F140-45x32.5x35	45" x 32.5" x 35" 62.5 lbs. (18" Seat Height)	-	✓	✓	✓	✓	-	✓	✓	✓	✓	✓	✓	✓	✓	✓	-	✓	✓	✓	✓	✓	-	✓

Fōmcore
SERVE. CREATE. INSPIRE.

1770 E. Keating Ave - Muskegon, MI 49442 • Tel: 231.366.4791 • www.fomcore.com

ADDITIONAL
RESOURCES



CLICK TO VIEW >