

# NEST SERIES LUG NEST

Product No. F129

Our patent pending Nest Series\* is where mindfulness and reflection meet. The Lug Nest\* is the perfect spot for a little alone time. Learners can tuck away in this sound dampening space to find a comfortable and safe space to sit, read and reflect. The solid foam construction allows for light-weight and easy movement.



## DETAILS

### CONSTRUCTION

- Solid foam construction
- Reinforced seams and stitching
- Fully zippered (no wood base)
- Patented\*
- Made in USA
- Backed with a lifetime warranty

### MODIFICATION

- Textile and placement
- Colored stitching
- Embroidery

## QUICK COMBOS

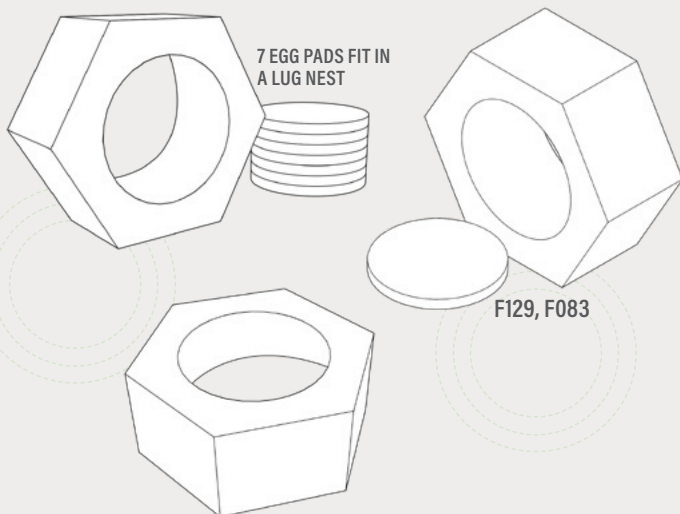

**Fōmcore**  
SERVE. CREATE. INSPIRE.

# HOW TO SPECIFY F129

## STEP 1: HEIGHT

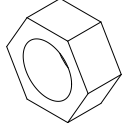
DIMENSION (L x W)	HEIGHT
 58.9" x 24"	51"

## STEP 2: FULLY ZIPPERED

### FULLY ZIPPERED



Fully Zippered (Z)

*\*Reference the product breakdown on back for availability.*

## STEP 3: GRADE AND TEXTILE

### GRADES & SWATCHES



[CLICK TO VIEW »](#)

### FABRIC DIRECTION & COLOR GUIDE



[CLICK TO VIEW »](#)

*\*Thread will default to match the seat textile.*

### COLOR GUIDE

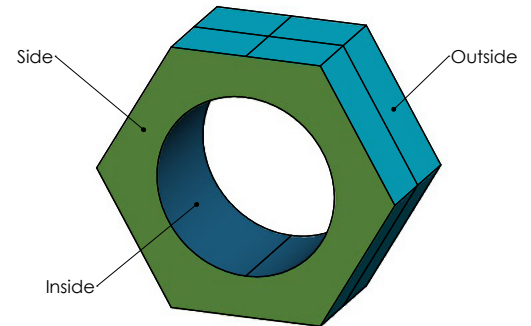

## STEP 4: ACCESSORIES (OPTIONAL)

### EMBROIDERY

- Personalize your furniture with embroidery!
- We can embroider logos up to 12" x 15".

### EMBROIDERY SPECS

[CLICK TO VIEW »](#)



### CAL TB-133

- Optional flame retardant add on.

*\*Reference the product breakdown on back for availability.*

## STEP 5: CONFIGURE PART NUMBER

### FILL IN YOUR PART NUMBER

F	1	2	9	-	5	8	.	x	2	4	x	5	1	-	Z		
FAMILY					STEP 1								STEP 2				
L					W				H				ZIP				

### EXAMPLE PART NUMBER

F	1	2	9	-	5	8	.	x	2	4	x	5	1	-	Z		
FAMILY					STEP 1								STEP 2				
L					W				H				ZIP				

## STEP 6: CONFIGURE DESCRIPTION

### FILL IN YOUR DESCRIPTION

#### 1. INSIDE

1. Inside				
LOCATION	GRADE	MANUFACTURER	PATTERN	COLOR

#### 2. SIDES

2. Side				
LOCATION	GRADE	MANUFACTURER	PATTERN	COLOR

#### 3. OUTSIDE

3. Outside				
LOCATION	GRADE	MANUFACTURER	PATTERN	COLOR

#### EMBROIDERY\*

Seat	
LOCATION	NAME

#### FIRE RETARDANCY\*

CAL TB-133
------------

STEP 3

### EXAMPLE DESCRIPTION

#### 1. INSIDE

1. Inside	1	Spradling	Silvertex	Sage
LOCATION	GRADE	MANUFACTURER	PATTERN	COLOR

#### 2. SIDES

2. Side	3	Momentum	Tribeca	Fossil
LOCATION	GRADE	MANUFACTURER	PATTERN	COLOR

#### 3. OUTSIDE

3. Outside	3	Momentum	Tribeca	Fossil
LOCATION	GRADE	MANUFACTURER	PATTERN	COLOR

#### EMBROIDERY\*

Seat	Rocket Logo
LOCATION	NAME

#### FIRE RETARDANCY\*

CAL TB-133
------------

\*Optional add-ons. Reference product breakdown for availability.

INCLUDE ON PURCHASE ORDER

## EXAMPLE CONFIGURATION

F129-58.9x24x51-Z

1. Inside: Grade 1, Spradling, Silvertex, Sage | 2. Sides: Grade 3, Momentum, Tribeca, Fossil  
 3. Outside: Grade 3, Momentum, Tribeca, Fossil | Embroidery: Seat, Rocket logo | CAL TB-133

## PRODUCT BREAKDOWN

### LUG NEST (F129)

Product No.	Dimen./Weight (L x W x H)	FOOT OPTIONS											INTEGRATED POWER OPTION								TFL	Emb.	
		Zip Z	Standard G1 L1		3" Premium R3 C3		6" Premium S16 S29 C6 T6 R6 M6				Standard G1 L1		3" Premium R3 C3		6" Premium S16 S29 C6 T6 R6 M6								
F129-58.9x24x51	58.9" x 24" x 51" 39 lbs.	✓	-	-	-	-	-	-	-	-	-	-	-	-	-	-	-	-	-	-	-	-	✓



ADDITIONAL RESOURCES



CLICK TO VIEW »