

# NETWORK SERIES TRIANGLE OTTOMAN

Product No. F114

With our light-weight, solid foam construction, you can maneuver the Triangle Ottoman into endless combinations. Meetings, gatherings, and even quick chats will flourish in your purposefully curated spaces. Showcasing the variety of geometry from the Triangle Ottoman, your creativity has no bounds to craft the proper environment for any situation.



Shown with 1" Nylon Glides

## DETAILS

### CONSTRUCTION

- Solid foam construction
- MDF baseboard to fit foot options
- Reinforced seams and stitching
- Made in USA
- Backed with a lifetime warranty

### MODIFICATION

- Textile and placement
- Leg and foot options
- Colored stitching
- TFL work surface
- Embroidery

## QUICK COMBOS

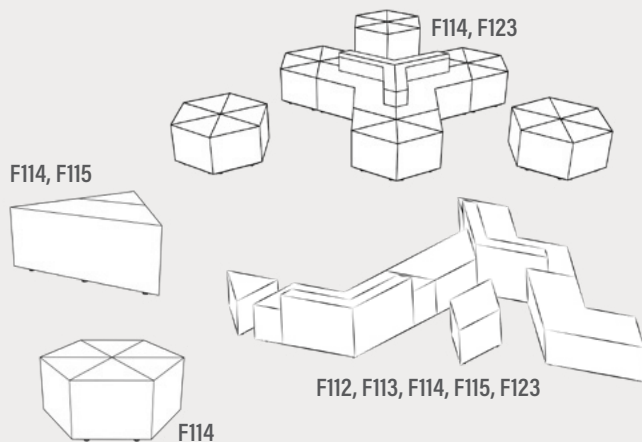

## HOW TO SPECIFY F114

### STEP 1: SEAT HEIGHT

DIMENSION (L x W)	SEAT HEIGHT
 20.75" x 18"	16"
	18"

### STEP 2: FOOT

#### 1" STANDARD FOOT OPTIONS

-  Nylon Glide (G1)
-  Felt Glide (G1)
-  1" Low Profile Leg (L1)  
Black

\*Reference the product breakdown on back for availability.

### STEP 3: GRADE AND TEXTILE

#### GRADES & SWATCHES



[CLICK TO VIEW »](#)

#### FABRIC DIRECTION & COLOR GUIDE





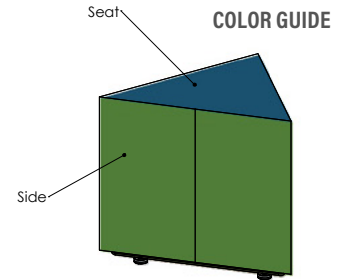



[CLICK TO VIEW »](#)



\*Thread will default to match the seat textile.

### STEP 4: ACCESSORIES (OPTIONAL)

#### TFL WORKSURFACE (TFL)

-  White Wood
-  Natural Maple
-  Dark Wood
-  Black Crystal
-  Fashion Grey
-  Marker Board

#### EMBROIDERY

- Personalize your furniture with embroidery!
- We can embroider logos up to 12" x 15".

#### EMBROIDERY SPECS

[CLICK TO VIEW »](#)



#### PASSES

- Optional flame retardant add on.

\*Reference the product breakdown on back for availability.

## STEP 5: CONFIGURE PART NUMBER

### FILL IN YOUR PART NUMBER

F	1	1	4	-				X				X				-					-				
FAMILY					L				W				H				FOOT				TFL				
STEP 1												STEP 2				STEP 4* (OPTIONAL)									

### EXAMPLE PART NUMBER

F	1	1	4	-	2	0	7	5	X	1	8	X	1	6	-	G	1	-	T	F	L			
FAMILY					L				W				H				FOOT				TFL			

## STEP 6: CONFIGURE DESCRIPTION

### FILL IN YOUR DESCRIPTION

#### 1. SEAT

1. Seat				
LOCATION	GRADE	MANUFACTURER	PATTERN	COLOR

#### 2. SIDE

2. Side				
LOCATION	GRADE	MANUFACTURER	PATTERN	COLOR

#### FOOT

1" Nylon Glide
NAME/COLOR

#### FIRE RETARDANCY\*

CAL TB-133
------------

#### TFL WORKSURFACE\*

White Wood
COLOR

#### EMBROIDERY\*

Seat	Rocket Logo
LOCATION	NAME

### EXAMPLE DESCRIPTION

#### 1. SEAT

1. Seat	1	Spradling	Silvertex	Sage
LOCATION	GRADE	MANUFACTURER	PATTERN	COLOR

#### 2. SIDE

2. Side	3	Momentum	Tribeca	Fossil
LOCATION	GRADE	MANUFACTURER	PATTERN	COLOR

#### FOOT

1" Nylon Glide
NAME/COLOR

#### FIRE RETARDANCY\*

CAL TB-133
------------

#### TFL WORKSURFACE\*

White Wood
COLOR

#### EMBROIDERY\*

Seat	Rocket Logo
LOCATION	NAME

\*Optional add-ons. Reference product breakdown for availability.

INCLUDE ON PURCHASE ORDER

## EXAMPLE CONFIGURATION

F114-20.75x18x16-G1-TFL

1. Seat: Grade 1, Spradling, Silvertex, Sage | 2. Side: Grade 3, Momentum, Tribeca, Fossil

Foot: 1" Nylon Glide | TFL Worksurface: White Wood | Embroidery: Seat, Rocket logo | CAL TB-133

## PRODUCT BREAKDOWN

### TRIANGLE OTTOMAN (F114)

Product No.	Dimen./Weight (L x W x H)	FOOT OPTIONS												INTEGRATED POWER OPTION												TFL	Emb.
		Zip		Standard		3" Premium		6" Premium				Standard		3" Premium		6" Premium											
		Z	G1	L1	R3	C3	S16	S29	C6	T6	R6	M6	G1	L1	R3	C3	S16	S29	C6	T6	R6	M6					
F114-20.75x18x16	20.75" x 18" x 16" 6 lbs.	-	✓	✓	-	-	-	-	-	-	-	-	-	-	-	-	-	-	-	-	-	-	-	✓	✓		
F114-20.75x18x18	20.75" x 18" x 18" 7 lbs.	-	✓	✓	-	-	-	-	-	-	-	-	-	-	-	-	-	-	-	-	-	-	-	✓	✓		



ADDITIONAL RESOURCES



CLICK TO VIEW »