

NETWORK SERIES

DIAMOND OTTOMAN

Product No. F112

With our light-weight, solid foam construction, you can maneuver the Diamond Ottoman into endless combinations. Meetings, gatherings, and even quick chats will flourish in your purposefully curated spaces. Showcasing the variety of geometry from the Diamond Ottoman, your creativity has no bounds to craft the proper environment for any situation.



DETAILS

CONSTRUCTION

- Solid foam construction
- MDF baseboard to fit foot options
- Reinforced seams and stitching
- Made in USA
- Backed with a lifetime warranty

MODIFICATION

- Textile and placement
- Leg and foot options
- Colored stitching
- TFL work surface
- Embroidery

QUICK COMBOS

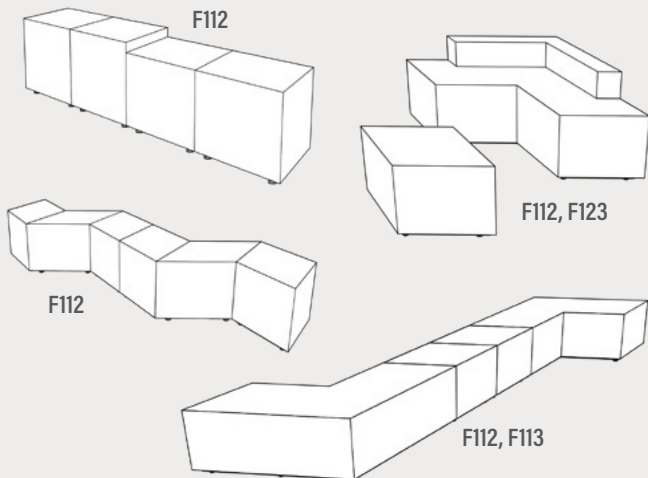

HOW TO SPECIFY F112

STEP 1: SEAT HEIGHT

DIMENSION (L x W)	SEAT HEIGHT
	16"
	18"

STEP 2: FOOT

1" STANDARD FOOT OPTIONS

- Nylon Glide (G1)
- Felt Glide (G1)
- 1" Low Profile Leg (L1)
Black

**Reference the product breakdown on back for availability.*

STEP 3: GRADE AND TEXTILE

GRADES & SWATCHES



[CLICK TO VIEW »](#)

FABRIC DIRECTION & COLOR GUIDE



[CLICK TO VIEW »](#)

**Thread will default to match the seat textile.*

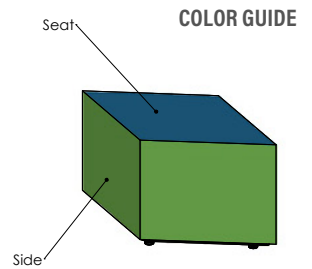

STEP 4: ACCESSORIES (OPTIONAL)

TFL WORKSURFACE (TFL)

- White Wood
- Natural Maple
- Dark Wood
- Black Crystal
- Fashion Grey
- Marker Board

EMBROIDERY

- Personalize your furniture with embroidery!
- We can embroider logos up to 12" x 15".

EMBROIDERY SPECS

[CLICK TO VIEW »](#)



CAL TB-133

- Optional flame retardant add on.

**Reference the product breakdown on back for availability.*

STEP 5: CONFIGURE PART NUMBER

FILL IN YOUR PART NUMBER

F	1	1	2	-	x	x	-			-		
FAMILY					L			W			H	
					FOOT			TFL				
					STEP 1			STEP 2			STEP 4* (OPTIONAL)	

EXAMPLE PART NUMBER

F	1	1	2	-	3	6	x	1	8	x	1	6	-	G	1	-	T	F	L
FAMILY					L			W			H			FOOT			TFL		

STEP 6: CONFIGURE DESCRIPTION

FILL IN YOUR DESCRIPTION

1. SEAT

1. Seat					
LOCATION	GRADE	MANUFACTURER	PATTERN	COLOR	

2. SIDE

2. Side					
LOCATION	GRADE	MANUFACTURER	PATTERN	COLOR	

FOOT

1" Nylon Glide
NAME/COLOR

TFL WORKSURFACE*

COLOR

EMBROIDERY*

LOCATION	NAME

FIRE RETARDANCY*

--

STEP 3

EXAMPLE DESCRIPTION

1. SEAT

1. Seat	1	Spradling	Silvertex	Sage
LOCATION	GRADE	MANUFACTURER	PATTERN	COLOR

2. SIDE

2. Side	3	Momentum	Tribeca	Fossil
LOCATION	GRADE	MANUFACTURER	PATTERN	COLOR

FOOT

1" Nylon Glide
NAME/COLOR

TFL WORKSURFACE*

White Wood
COLOR

EMBROIDERY*

Seat	Rocket Logo
LOCATION	NAME

FIRE RETARDANCY*

CAL TB-133

*Optional add-ons. Reference product breakdown for availability.

INCLUDE ON PURCHASE ORDER

EXAMPLE CONFIGURATION

F112-36x18x16-G1-TFL

1. Seat: Grade 1, Spradling, Silvertex, Sage | 2. Side: Grade 3, Momentum, Tribeca, Fossil

Foot: 1" Nylon Glide | TFL Worksurface: White Wood | Embroidery: Seat, Rocket logo | CAL TB-133

PRODUCT BREAKDOWN

DIAMOND OTTOMAN (F112)

Product No.	Dimen./Weight (L x W x H)	FOOT OPTIONS												INTEGRATED POWER OPTION										TFL	Emb.
		Zip	Standard			3" Premium		6" Premium						Standard		3" Premium		6" Premium							
		Z	G1	L1	R3	C3	S16	S29	C6	T6	R6	M6	G1	L1	R3	C3	S16	S29	C6	T6	R6	M6			
F112-36x18x16	36" x 18" x 16" 10 lbs.	-	✓	✓	-	-	-	-	-	-	-	-	-	-	-	-	-	-	-	-	-	-	-	✓	✓
F112-36x18x18	36" x 18" x 18" 122 lbs.	-	✓	✓	-	-	-	-	-	-	-	-	-	-	-	-	-	-	-	-	-	-	-	✓	✓

Fōmcore
SERVE. CREATE. INSPIRE.

ADDITIONAL
RESOURCES



CLICK TO VIEW »