

NEST SERIES

FALCON'S/HEX EGG PAD

Product No. F084

The Falcon's/Hex Egg Pad is a comfortable seating option for when sitting on the floor. The versatile piece can be used on its own or can be placed into the center of a Falcon or Hex Nest to create a quiet space.



DETAILS

CONSTRUCTION

- Solid foam construction
- Fully zippered (no wood base)
- Reinforced seams and stitching
- Made in USA
- Backed with a lifetime warranty

MODIFICATION

- Textile and placement
- Colored stitching and zipper
- Embroidery

QUICK COMBOS

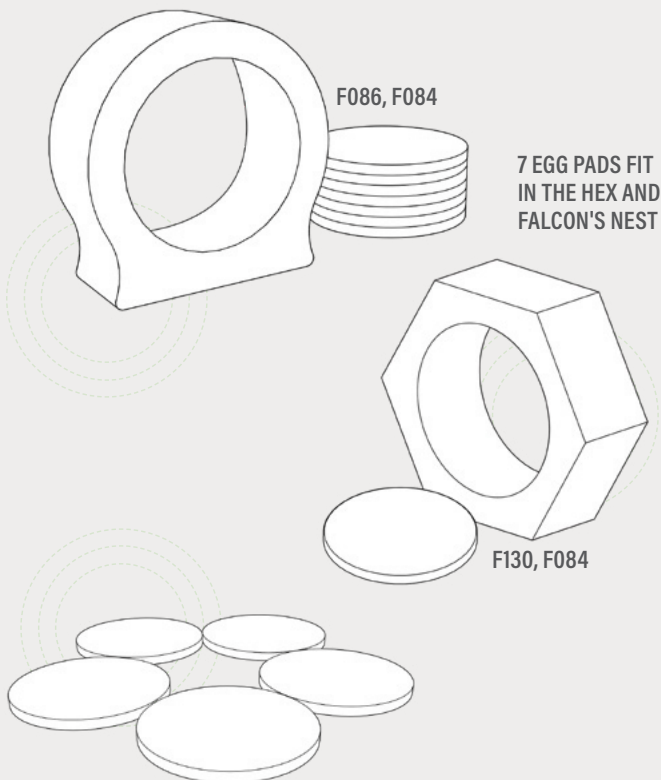

HOW TO SPECIFY F084

STEP 1: SEAT HEIGHT

DIMENSION (DIA x H)	SEAT HEIGHT
 47"	3"

STEP 2: FULLY ZIPPERED

FULLY ZIPPERED



Fully Zippered (Z)

**Reference the product breakdown on back for availability.*

STEP 3: GRADE AND TEXTILE

GRADES & SWATCHES



[CLICK TO VIEW »](#)

ONE COLOR STANDARD

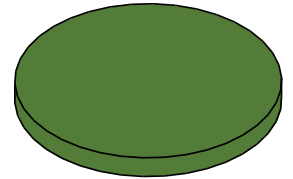

**Thread will default to match the seat textile.*

STEP 4: ACCESSORIES (OPTIONAL)

EMBROIDERY

- Personalize your furniture with embroidery!
- We can embroider logos up to 12" x 15".

EMBROIDERY SPECS

[CLICK TO VIEW »](#)



CAL TB-133

- Optional flame retardant add on.

**Reference the product breakdown on back for availability.*



STEP 5: CONFIGURE PART NUMBER

FILL IN YOUR PART NUMBER

F	0	8	4	-	4	7	x	3	-	Z			
FAMILY					DIA				H		ZIP		
STEP 1									STEP 2				

EXAMPLE PART NUMBER

F	0	8	4	-	4	7	x	3	-	Z			
FAMILY					DIA				H		ZIP		

STEP 6: CONFIGURE DESCRIPTION

FILL IN YOUR DESCRIPTION

1. SEAT

1. Seat					
LOCATION	GRADE	MANUFACTURER	PATTERN	COLOR	

2. SIDE

2. Side					
LOCATION	GRADE	MANUFACTURER	PATTERN	COLOR	

EMBROIDERY*

LOCATION	NAME

FIRE RETARDANCY*

--

STEP 3

EXAMPLE DESCRIPTION

1. SEAT

1. Seat	1	Spradling	Silvertex	Sage
LOCATION	GRADE	MANUFACTURER	PATTERN	COLOR

2. SIDE

2. Side	3	Momentum	Tribeca	Fossil
LOCATION	GRADE	MANUFACTURER	PATTERN	COLOR

EMBROIDERY*

Seat	Rocket Logo
LOCATION	NAME

FIRE RETARDANCY*

CAL TB-133

*Optional add-ons. Reference product breakdown for availability.

INCLUDE ON PURCHASE ORDER

EXAMPLE CONFIGURATION

F084-47x3-Z

1. Seat: Grade 1, Spradling, Silvertex, Sage | 2. Side: Grade 3, Momentum, Tribeca, Fossil

Embroidery: Seat, Rocket logo | CAL TB-133

PRODUCT BREAKDOWN

FALCON'S/HEX EGG PAD (F084)

Product No.	Dimen./Weight (Dia. x H)	Zip Z	FOOT OPTIONS										INTEGRATED POWER OPTION						TFL	Emb.					
			Standard		3" Premium		6" Premium						Standard		3" Premium		6" Premium								
			G1	L1	R3	C3	S16	S29	C6	T6	R6	M6	G1	L1	R3	C3	S16	S29	C6	T6	R6	M6			
F084-47x3	47" x 3" 5 lbs.	✓	-	-	-	-	-	-	-	-	-	-	-	-	-	-	-	-	-	-	-	-	-	-	✓



1770 E. Keating Ave - Muskegon, MI 49442 • Tel: 231.366.4791 • www.fomcore.com

ADDITIONAL RESOURCES



CLICK TO VIEW »