

# OTTOMAN & BENCH SERIES BOWTIE BENCH

Product No. F077

Our Bowtie Bench is a unique shape that can bring added style to the space. You can use 5 Bowtie Benches and an ottoman to make a Bowtie Combo to make a collaboration space.



Shown with 1" Nylon Glides

## DETAILS

### CONSTRUCTION

- Solid foam construction
- MDF baseboard to fit foot options
- Reinforced seams and stitching
- Made in USA
- Backed with a lifetime warranty

### MODIFICATION

- Seat height
- Textile and placement
- Leg, caster, and foot options
- Fully zippered (no wood base)
- Colored stitching and zipper
- Embroidery

## QUICK COMBOS

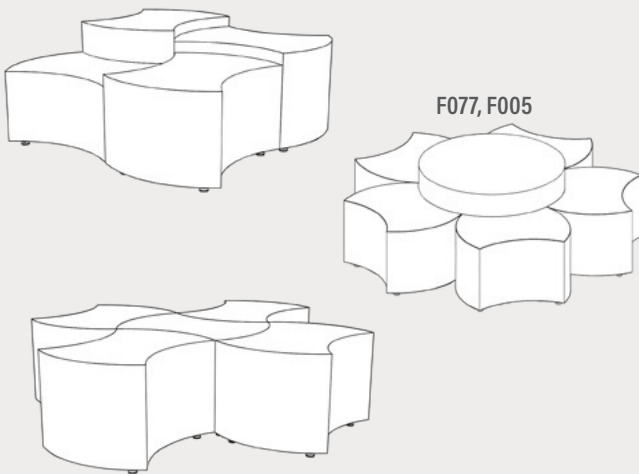

F077, F005

# HOW TO SPECIFY F077

## STEP 1: SEAT HEIGHT

DIMENSION (L x W)	SEAT HEIGHT
	14"
	16"
	18"
	20"

## STEP 2: FOOT AND FULLY ZIPPERED

### FULLY ZIPPERED



### 1" STANDARD FOOT OPTIONS

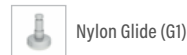

### 3" PREMIUM FOOT OPTIONS



### 6" PREMIUM FOOT OPTIONS

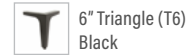

\*Reference the product breakdown on back for availability.

## STEP 3: GRADE AND TEXTILE

### GRADES & SWATCHES



[CLICK TO VIEW »](#)

### FABRIC DIRECTION & COLOR GUIDE



[CLICK TO VIEW »](#)

\*Thread will default to match the seat textile.

### COLOR GUIDE

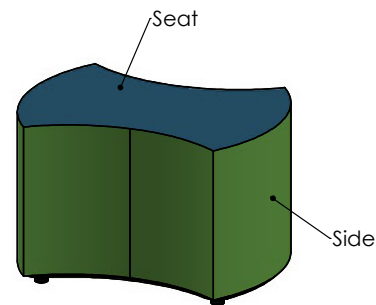

## STEP 4: ACCESSORIES (OPTIONAL)

### EMBROIDERY

- Personalize your furniture with embroidery!
- We can embroider logos up to 12" x 15".

### CAL TB-133

- Optional flame retardant add on.

### EMBROIDERY SPECS

[CLICK TO VIEW »](#)



\*Reference the product breakdown on back for availability.

## STEP 5: CONFIGURE PART NUMBER

### FILL IN YOUR PART NUMBER

F	0	7	7	-		x		x		-			
FAMILY					STEP 1				STEP 2				
L					W				H				
FOOT/ZIP													

### EXAMPLE PART NUMBER

F	0	7	7	-	2	8	x	2	1	x	1	4	-	R	6			
FAMILY					L				W				H				FOOT/ZIP	

## STEP 6: CONFIGURE DESCRIPTION

### FILL IN YOUR DESCRIPTION

#### 1. SEAT

1. Seat					
LOCATION	GRADE	MANUFACTURER	PATTERN	COLOR	

#### 2. SIDE

2. Side					
LOCATION	GRADE	MANUFACTURER	PATTERN	COLOR	

#### FOOT

NAME/COLOR
------------

#### FIRE RETARDANCY\*

--

#### EMBROIDERY\*

LOCATION	NAME
----------	------

STEP 3

### EXAMPLE DESCRIPTION

#### 1. SEAT

1. Seat	1	Spradling	Silvertex	Sage
LOCATION	GRADE	MANUFACTURER	PATTERN	COLOR

#### 2. SIDE

2. Side	3	Momentum	Tribeca	Fossil
LOCATION	GRADE	MANUFACTURER	PATTERN	COLOR

#### FOOT

6" Rectangle Leg - Black
--------------------------

#### FIRE RETARDANCY\*

CAL TB-133
------------

#### NAME/COLOR

Seat	Rocket Logo
------	-------------

#### EMBROIDERY\*

Seat	Rocket Logo
LOCATION	NAME

\*Optional add-ons. Reference product breakdown for availability.

INCLUDE ON PURCHASE ORDER

## EXAMPLE CONFIGURATION

F077-28x21x14-R6

1. Seat: Grade 1, Spradling, Silvertex, Sage | 2. Side: Grade 3, Momentum, Tribeca, Fossil

Foot: 6" Rectangle Leg Black | Embroidery: Seat, Rocket logo | CAL TB-133

## PRODUCT BREAKDOWN

### BOWTIE BENCH (F077)

Product No.	Dimen./Weight (L x W x H)	FOOT OPTIONS											INTEGRATED POWER OPTION								TFL	Emb.			
		Zip	Standard		3" Premium		6" Premium				Standard		3" Premium		6" Premium										
		Z	G1	L1	R3	C3	S16	S29	C6	T6	R6	M6	G1	L1	R3	C3	S16	S29	C6	T6			R6	M6	
F077-28x21x14	28" x 21" x 14" 12 lbs.	✓	✓	✓	✓	✓	-	-	-	✓	✓	✓	-	-	-	-	-	-	-	-	-	-	-	-	✓
F077-28x21x16	28" x 21" x 16" 13 lbs.	✓	✓	✓	✓	✓	-	-	-	✓	✓	✓	-	-	-	-	-	-	-	-	-	-	-	-	✓
F077-28x21x18	28" x 21" x 18" 14 lbs.	✓	✓	✓	✓	✓	-	-	-	✓	✓	✓	-	-	-	-	-	-	-	-	-	-	-	-	✓
F077-28x21x20	28" x 21" x 20" 15 lbs.	✓	✓	✓	✓	✓	-	-	-	✓	✓	✓	-	-	-	-	-	-	-	-	-	-	-	-	✓



#### ADDITIONAL RESOURCES



CLICK TO VIEW »