

STEP SERIES

THREE STEP INSIDE CORNER

Product No. F035

Since the Three Step Inside Corner is made of solid foam, it's light and convenient to move around and no hard edges. With the Step line you can fit them together for collaboration, tiered seating, or even small groups by simply shifting them around.

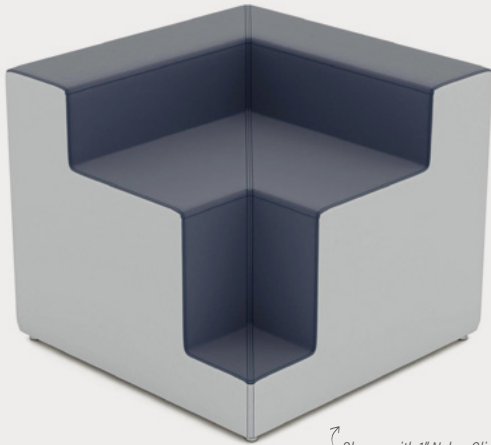

Shown with 1" Nylon Glides

DETAILS

CONSTRUCTION

- Solid foam construction
- MDF baseboard to fit foot options
- Reinforced seams and stitching
- Made in USA
- Backed with a lifetime warranty

MODIFICATION

- Seat height
- Textile and placement
- Leg and foot options
- Colored stitching and zipper
- Embroidery
- Power

QUICK COMBOS

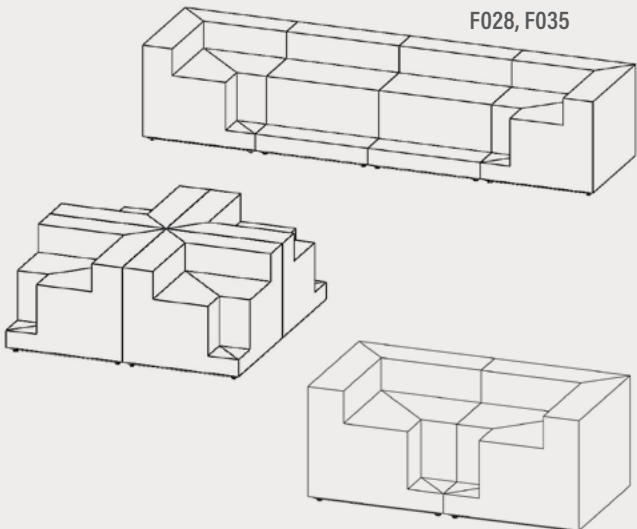

HOW TO SPECIFY F035

STEP 1: SEAT HEIGHT

DIMENSION (L x W)	HEIGHT	STEP 1 HEIGHT	STEP 2 HEIGHT
38" x 38"	32"	7"	23"

STEP 2: FOOT

1" STANDARD FOOT OPTIONS

- Nylon Glide (G1)
- Felt Glide (G1)
- 1" Low Profile Leg (L1)
Black

*Reference the product breakdown on back for availability.

STEP 3: GRADE AND TEXTILE

GRADES & SWATCHES FABRIC DIRECTON & COLOR GUIDE

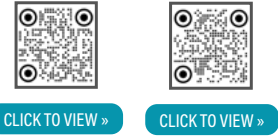

*Thread will default to match the seat textile.

COLOR GUIDE

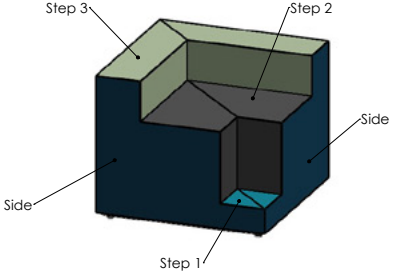

STEP 4: ACCESSORIES (OPTIONAL)

INTEGRATED POWER OPTIONS* (PI, PI+)

- White
- Silver
- PI = 1 Power Unit
- PI+ = 2 Power Units

EMBROIDERY

- Personalize your furniture with embroidery!
- We can embroider logos up to 12" x 15".

EMBROIDERY SPECS

[CLICK TO VIEW >](#)



CAL TB-133

- Optional flame retardant add on.

*Reference the product breakdown on back for availability.



STEP 5: CONFIGURE PART NUMBER

FILL IN YOUR PART NUMBER

F	0	3	5	-	3	8	x	3	8	x	3	2	-				-					
FAMILY					L				W				H				FOOT			POWER		
STEP 1												STEP 2			STEP 4* (OPTIONAL)							

EXAMPLE PART NUMBER

F	0	3	5	-	3	8	x	3	8	x	3	2	-	L	1	-	P	1		
FAMILY					L				W				H				FOOT		POWER	

STEP 6: CONFIGURE DESCRIPTION

FILL IN YOUR DESCRIPTION

1. SEAT

1. Seat					
LOCATION	GRADE	MANUFACTURER	PATTERN	COLOR	

2. SIDE

2. Side					
LOCATION	GRADE	MANUFACTURER	PATTERN	COLOR	

FOOT

NAME/COLOR

POWER*

COLOR	QUANTITY
-------	----------

EMBROIDERY*

LOCATION	NAME
----------	------

STEP 3

EXAMPLE DESCRIPTION

1. SEAT

1. Seat	1	Spradling	Silvertex	Sage
LOCATION	GRADE	MANUFACTURER	PATTERN	COLOR

2. SIDE

2. Side	3	Momentum	Tribeca	Fossil
LOCATION	GRADE	MANUFACTURER	PATTERN	COLOR

FOOT

6" Rectangle Leg - Black	White	1
NAME/COLOR	COLOR	QUANTITY

EMBROIDERY*

Seat	Rocket Logo
LOCATION	NAME

*Optional add-ons. Reference product breakdown for availability.

INCLUDE ON PURCHASE ORDER

EXAMPLE CONFIGURATION

F035-38x38x32-L1

1. Seat: Grade 1, Spradling, Silvertex, Sage | 2. Side: Grade 3, Momentum, Tribeca, Fossil

Foot: 1" Low Profile Black Leg | Embroidery: Seat, Rocket logo

PRODUCT BREAKDOWN

THREE STEP INSIDE CORNER (F035)

Product No.	Dimen./Weight (L x W x H)	FOOT OPTIONS											INTEGRATED POWER OPTION								TFL	Emb.				
		Zip	Standard			3" Premium		6" Premium						Standard		6" Premium										
		Z	G1	L1	R3	C3	S16	S29	C6	T6	R6	M6	G1	L1	R3	C3	S16	S29	C6	T6			R6	M6		
F035-38x38x32	38" x 38" x 32" 46.5 lbs.	-	✓	✓	-	-	-	-	-	-	-	-	✓	✓	-	-	-	-	-	-	-	-	-	-	-	✓

Fōmcore
SERVE. CREATE. INSPIRE.

1770 E. Keating Ave - Muskegon, MI 49442 • Tel: 231.366.4791 • www.fomcore.com

ADDITIONAL
RESOURCES



CLICK TO VIEW »