

CREATE YOUR COMBO TRAIN STATION 2 COMBO

Product Numbers F016, F062



DETAILS

CONSTRUCTION

- Solid foam construction
- Wood base to fit foot options
- Reinforced seams and stitching
- Made in USA
- Backed with a lifetime warranty
- Waterfall edge

MODIFICATION

- Seat height
- Textile and placement
- Foot and finish options
- Stitching color
- Embroidery

COMBO BREAKDOWN

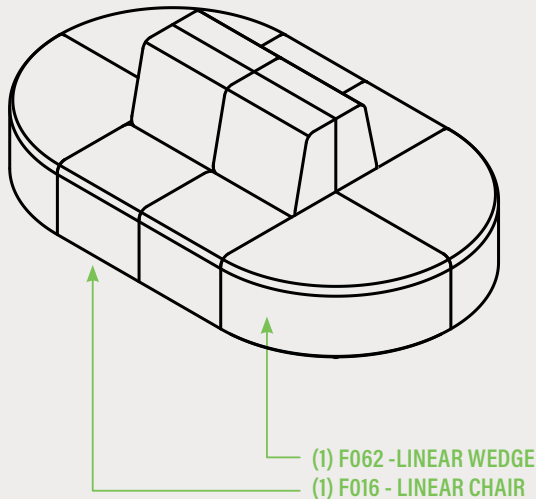

HOW TO SPECIFY A TRAIN STATION

STEP 1: SEAT HEIGHT

LINEAR CHAIR		LINEAR WEDGE	
DIMENSION (L x W x H)	SEAT HEIGHT	DIMENSION (L x W x H)	SEAT HEIGHT
14" x 20" x 23"	12"	20" x 20" x 12"	12"
17" x 23.5" x 27"	14"	23.5" x 23.5" x 14"	14"
22" x 31" x 35"	18"	31" x 31" x 18"	18"

STEP 2: FOOT AND FULLY ZIPPERED

1" STANDARD FOOT OPTIONS

- Nylon Glide (G1)
- Felt Glide (G1)
- 1" Low Profile Leg (L1)
Black

3" PREMIUM FOOT OPTIONS

- 3" Rectangle (R3)
Black
- 3" Rectangle (R3)
Silver
- 3" Caster (C3)

6" PREMIUM FOOT OPTIONS

- Large Sled Leg (S29)
Silver
- Large Sled Leg (S29)
Black
- 6" Mod Leg (M6)
- 6" Rectangle (R6)
Black
- 6" Rectangle (R6)
Silver
- 6" Triangle (T6)
Black
- 6" Triangle (T6)
Silver
- 6" Caster (C6)

*Reference the product breakdown on back for availability.

STEP 3: GRADE AND TEXTILE

GRADES & SWATCHES



[CLICK TO VIEW »](#)

FABRIC DIRECTION & COLOR GUIDES

LINEAR CHAIR



[CLICK TO VIEW »](#)

LINEAR WEDGE



[CLICK TO VIEW »](#)

*Thread will default to match the seat textile.

COLOR GUIDES

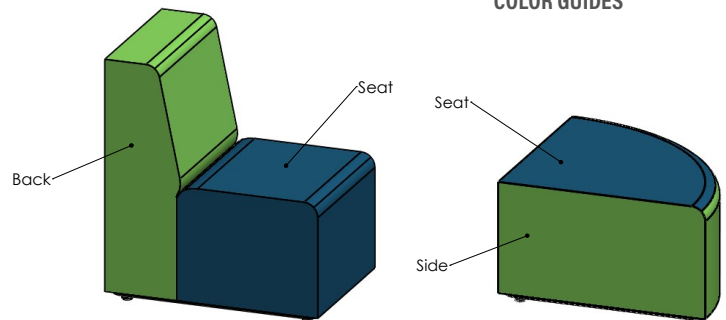

STEP 4: MODIFICATIONS (OPTIONAL)

EMBROIDERY

- Personalize your furniture with embroidery!
- We can embroider up to 12" x 15" artwork

EMBROIDERY SPECS

[CLICK TO VIEW »](#)



FLAME RETARDANT

- CAL TB-133
- Optional flame retardant add on.

*Reference the product breakdown on back for availability.

STEP 5: CONFIGURE PART NUMBER

FILL IN YOUR PART NUMBER

					-			x			x			-			
FAMILY						STEP 1							STEP 2				
L						W			H				FOOT/ZIP				

EXAMPLE PART NUMBER

F	0	1	6	-	2	2	x	3	2	x	3	5	-	G	1
FAMILY					L			W				H		FOOT/ZIP	

STEP 6: CONFIGURE DESCRIPTION

FILL IN YOUR DESCRIPTION

1. SEAT

1. Seat					
LOCATION	GRADE	MANUFACTURER	PATTERN	COLOR	

2. SIDE

2. Side					
LOCATION	GRADE	MANUFACTURER	PATTERN	COLOR	

FOOT

NAME/COLOR

EMBROIDERY*

LOCATION	NAME

FLAME RETARDANT*

--

STEP 3

EXAMPLE DESCRIPTION

1. SEAT

1. Seat	1	Spradling	Silvertex	Sage
LOCATION	GRADE	MANUFACTURER	PATTERN	COLOR

2. SIDE

2. Side	3	Momentum	Tribeca	Fossil
LOCATION	GRADE	MANUFACTURER	PATTERN	COLOR

FOOT

1" Nylon Glide	Seat	Rocket Logo
NAME/COLOR	LOCATION	NAME

FLAME RETARDANT*

CAL TB-133

*Optional add-ons. Reference product breakdown for availability.

INCLUDE ON PURCHASE ORDER

REPEAT STEP 5 & 6 FOR EACH PRODUCT NUMBER.

EXAMPLE CONFIGURATION

F016-22x31x33-G1

1. Seat: Grade 1, Spradling, Silvertex, Sage | 2. Side: Grade 3, Momentum, Tribeca, Fossil

Foot: 1" Nylon Glide | Embroidery: Seat, Rocket logo | CAL TB-133

PRODUCT BREAKDOWN

TRAIN STATION 2 COMBO

Description/ Product No.	Dimen./Weight (L x W x H)	FOOT AND FINISH OPTIONS												INTEGRATED POWER OPTIONS						HPL	Emb.					
		Zip Z	Standard		3" Premium		6" Premium						Standard		3" Premium		6" Premium									
			G1	L1	R3	C3	S16	S29	C6	T6	R6	M6	G1	L1	R3	C3	S16	S29	C6			T6	R6	M6		
Linear Chair F016-14x20x23	14" x 20" x 23" 8 lbs. (12" Seat Height)	-	✓	✓	✓	✓	-	-	-	-	-	-	-	-	-	-	-	-	-	-	-	-	-	-	-	✓
Linear Chair F016-17x23.5x27	17" x 23.5" x 27" 12 lbs. (14" Seat Height)	-	✓	✓	✓	✓	-	-	-	-	-	-	-	✓	✓	✓	✓	-	-	-	-	-	-	-	-	✓
Linear Chair F016-22x31x35	22" x 31" x 35" 24 lbs. (18" Seat Height)	-	✓	✓	✓	✓	-	✓	✓	✓	✓	✓	✓	✓	✓	✓	✓	-	✓	✓	✓	✓	✓	✓	-	✓
Linear Wedge F062-20x20x12	20" x 20" x 12" 8 lbs.	-	✓	✓	✓	✓	-	-	-	-	-	-	-	-	-	-	-	-	-	-	-	-	-	-	-	✓
Linear Wedge F062-23.5x23.5x14	23.5" x 23.5" x 14" 12 lbs.	-	✓	✓	✓	✓	-	-	-	✓	✓	✓	-	-	-	-	-	-	-	-	-	-	-	-	-	✓
Linear Wedge F062-31x31x18	31" x 31" x 18" 22 lbs.	-	✓	✓	✓	✓	-	-	✓	✓	✓	✓	-	-	-	-	-	-	-	-	-	-	-	-	-	✓

Fōmcore
SERVE. CREATE. INSPIRE.

1770 E. Keating Ave - Muskegon, MI 49442 • Tel: 231.366.4791 • www.fomcore.com

ADDITIONAL
RESOURCES



CLICK TO VIEW »