

CREATE YOUR COMBO RAINBOW BENCH COMBO

Product Numbers F570, F571, F572

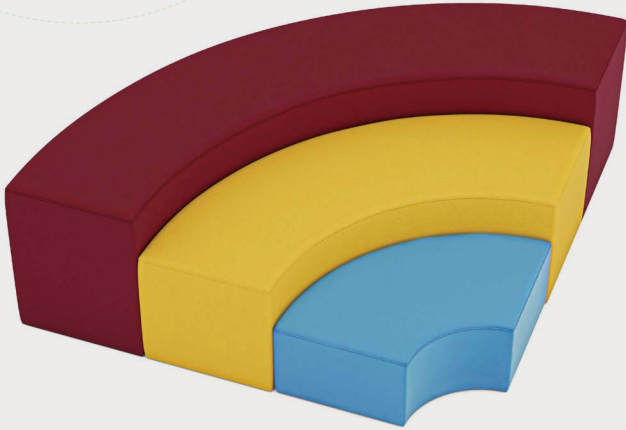

DETAILS

CONSTRUCTION

- Solid foam construction
- Wood base to fit foot options
- Reinforced seams and stitching
- Made in USA
- Backed with a lifetime warranty

MODIFICATION

- Seat height
- Textile and placement
- Foot and finish options
- Fully zippered (no wood base)
- Stitching and zipper color
- Embroidery

COMBO BREAKDOWN

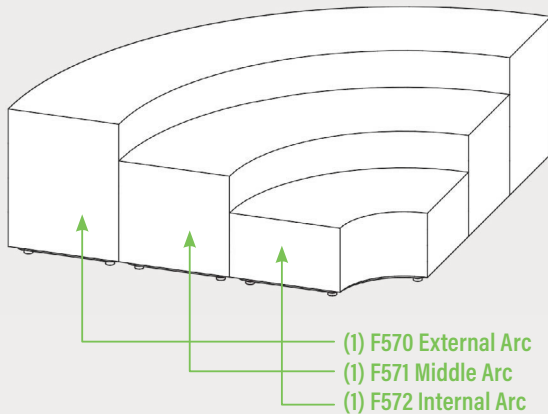

HOW TO SPECIFY A RAINBOW BENCH

STEP 1: SEAT HEIGHT

EXTERNAL ARC		MIDDLE ARC		INTERNAL ARC	
DIMENSION (L x W)	HEIGHT	DIMENSION (L x W)	HEIGHT	DIMENSION (L x W)	HEIGHT
91" x 18"	24"	65.5" x 18"	18"	40" x 18"	12"

STEP 2: FOOT AND FULLY ZIPPERED

FULLY ZIPPERED



Fully Zippered (Z)

**Reference the product breakdown on back for availability.*

1" STANDARD FOOT OPTIONS



Nylon Glide (G1)



Felt Glide (G1)



1" Low Profile Leg (L1)
Black

STEP 3: GRADE AND TEXTILE

GRADES & SWATCHES



[CLICK TO VIEW »](#)

FABRIC DIRECTON & COLOR GUIDE



[CLICK TO VIEW »](#)

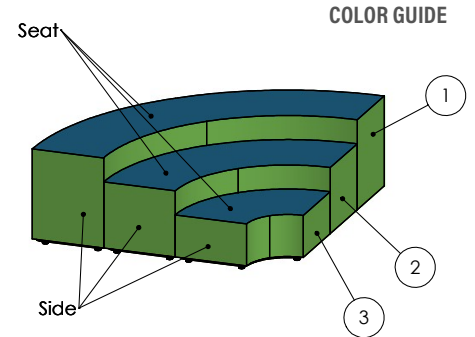

**Thread will default to match the seat textile.*

STEP 4: MODIFICATIONS (OPTIONAL)

EMBROIDERY

- Personalize your furniture with embroidery!
- We can embroider up to 12" x 15" artwork

EMBROIDERY SPECS

[CLICK TO VIEW »](#)



FLAME RETARDANT

- CAL TB-133
- Optional flame retardant add on.

**Reference the product breakdown on back for availability.*

STEP 5: CONFIGURE PART NUMBER

FILL IN YOUR PART NUMBER

					-			x			x				-					
FAMILY						STEP 1									STEP 2					
L						W			H			FOOT/ZIP								

EXAMPLE PART NUMBER

F	5	7	0	-	9	1	x	1	8	x	2	4	-	G	1
FAMILY					L			W			H			FOOT/ZIP	

STEP 6: CONFIGURE DESCRIPTION

FILL IN YOUR DESCRIPTION

1. SEAT

1. Seat					
LOCATION	GRADE	MANUFACTURER	PATTERN	COLOR	

2. SIDE

2. Side					
LOCATION	GRADE	MANUFACTURER	PATTERN	COLOR	

FOOT

NAME/COLOR

EMBROIDERY*

LOCATION	NAME

FLAME RETARDANT*

--

STEP 3

EXAMPLE DESCRIPTION

1. SEAT

1. Seat	1	Spradling	Silvertex	Sage
LOCATION	GRADE	MANUFACTURER	PATTERN	COLOR

2. SIDE

2. Side	3	Momentum	Tribeca	Fossil
LOCATION	GRADE	MANUFACTURER	PATTERN	COLOR

FOOT

1" Nylon Glide	Seat	Rocket Logo
NAME/COLOR	LOCATION	NAME

FLAME RETARDANT*

CAL TB-133

*Optional add-ons. Reference product breakdown for availability.

INCLUDE ON PURCHASE ORDER

REPEAT STEP 5 & 6 FOR EACH PRODUCT NUMBER.

EXAMPLE CONFIGURATION

F570-91x18x24-G1

1. Seat: Grade 1, Spradling, Silvertex, Sage | 2. Side: Grade 3, Momentum, Tribeca, Fossil

Foot: 1" Nylon Glide | Embroidery: Seat, Rocket logo

PRODUCT BREAKDOWN

RAINBOW BENCH COMBO

Description/ Product No.	Dimen./Weight (L x W x H)	FOOT OPTIONS												INTEGRATED POWER OPTION						HPL	Emb.				
		Zip		Standard		3" Premium		6" Premium				Standard		3" Premium		6" Premium									
		Z	G1	L1	R3	C3	S16	S29	C6	T6	R6	M6	G1	L1	R3	C3	S16	S29	C6			T6	R6	M6	
External Arc F570-91x18x24	91" x 18" x 24" 57 lbs.	✓	✓	✓	-	-	-	-	-	-	-	-	-	-	-	-	-	-	-	-	-	-	-	-	✓
Middle Arc F571-65.5x18x18	65.5" x 18" x 18" 32 lbs.	✓	✓	✓	-	-	-	-	-	-	-	-	-	-	-	-	-	-	-	-	-	-	-	-	✓
Internal Arc F572-40x18x12	40" x 18" x 12" 22 lbs.	✓	✓	✓	-	-	-	-	-	-	-	-	-	-	-	-	-	-	-	-	-	-	-	-	✓

Fōmcore
SERVE. CREATE. INSPIRE.

1770 E. Keating Ave - Muskegon, MI 49442 • Tel: 231.366.4791 • www.fomcore.com

ADDITIONAL
RESOURCES



CLICK TO VIEW >