

CONNECT SERIES

CONNECT LOW BACK SOFA

Product No. F133

Create. Collaborate. Connect. The Connect Low Back Sofa has a simple design allowing for various arrangements with the rest of the series. The Low Back Sofa has the same seat height as the rest of the Connect Series.



DETAILS

CONSTRUCTION

- Solid foam construction
- Wood base to fit foot options
- Reinforced seams and stitching
- Made in USA
- Backed with a lifetime warranty

MODIFICATION

- Textile and placement
- Foot and finish options
- Stitching color
- Embroidery
- Power options

QUICK COMBOS

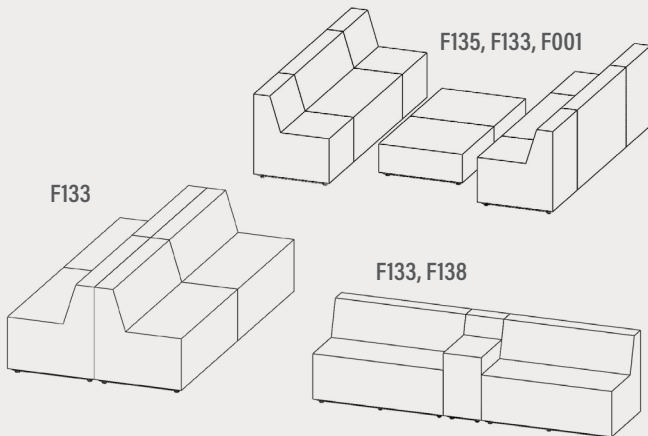

HOW TO SPECIFY F133

STEP 1: SEAT HEIGHT

DIMENSION (L x W)	HEIGHT	SEAT HEIGHT
	31"	18"

STEP 2: FOOT

1" STANDARD FOOT OPTIONS

- Nylon Glide (G1)
- Felt Glide (G1)
-

3" PREMIUM FOOT OPTIONS

-
-
-

6" PREMIUM FOOT OPTIONS

-
-
-
-
-
-

*Reference the product breakdown on back for availability.

STEP 3: GRADE AND TEXTILE

GRADES & SWATCHES



[CLICK TO VIEW »](#)

FABRIC DIRECTION & COLOR GUIDE



[CLICK TO VIEW »](#)

COLOR GUIDE

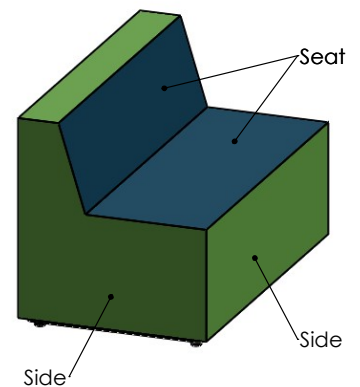

*Thread will default to match the seat textile.

STEP 4: MODIFICATIONS (OPTIONAL)

INTEGRATED POWER OPTIONS* (PI, PI+)

- White
- Silver

PI = 1 Power Unit
PI+ = 2 Power Units

EMBROIDERY

- Personalize your furniture with embroidery!
- We can embroider up to 12" x 15" artwork

EMBROIDERY SPECS

[CLICK TO VIEW »](#)



FLAME RETARDANT

- CAL TB-133
- Optional flame retardant add on.

*Reference the product breakdown on back for availability.

STEP 5: CONFIGURE PART NUMBER

FILL IN YOUR PART NUMBER

F	1	3	3	-	4	8	x	2	8	x	3	1	-					-				
FAMILY					STEP 1								STEP 2				STEP 4* (OPTIONAL)					
L					W				H				FOOT				POWER					

EXAMPLE PART NUMBER

F	1	3	3	-	4	8	x	2	8	x	3	1	-	R	6	-	P	1						
FAMILY					L								W				H				FOOT		POWER	

STEP 6: CONFIGURE DESCRIPTION

FILL IN YOUR DESCRIPTION

1. SEAT

1. Seat					
LOCATION	GRADE	MANUFACTURER	PATTERN	COLOR	

2. SIDE

2. Side					
LOCATION	GRADE	MANUFACTURER	PATTERN	COLOR	

FOOT

NAME/COLOR

POWER*

COLOR	QUANTITY
-------	----------

EMBROIDERY*

LOCATION	NAME
----------	------

FIRE RETARDANCY*

--

STEP 3

EXAMPLE DESCRIPTION

1. SEAT

1. Seat	1	Spradling	Silvertex	Sage
LOCATION	GRADE	MANUFACTURER	PATTERN	COLOR

2. SIDE

2. Side	3	Momentum	Tribeca	Fossil
LOCATION	GRADE	MANUFACTURER	PATTERN	COLOR

FOOT

6" Rectangle Leg - Black	White	1
NAME/COLOR	COLOR	QUANTITY

EMBROIDERY*

Seat	Rocket Logo
LOCATION	NAME

FIRE RETARDANCY*

CAL TB-133

*Optional add-ons. Reference product breakdown for availability.

INCLUDE ON PURCHASE ORDER

EXAMPLE CONFIGURATION

F133-48x28x31-R6-P1

1. Seat: Grade 1, Spradling, Silvertex, Sage | 2. Side: Grade 3, Momentum, Tribeca, Fossil

Foot: 6" Rectangle Leg Black | Power: White, Quantity: 1 | Embroidery: Seat, Rocket logo | CAL TB-133

PRODUCT BREAKDOWN

CONNECT LOW BACK SOFA (F133)

Product No.	Dimen./Weight (L x W x H)	FOOT OPTIONS										INTEGRATED POWER OPTION						HPL	Emb.				
		Zip Z	Standard		3" Premium		6" Premium						Standard		3" Premium		6" Premium						
			G1	L1	R3	C3	S16	S29	C6	T6	R6	M6	G1	L1	R3	C3	S16			S29	C6	T6	R6
F133-48x28x31	48" x 28" x 31" 53 lbs. (18" Seat Height)	-	✓	✓	✓	✓	-	-	✓	✓	✓	✓	✓	✓	✓	-	-	✓	✓	✓	✓	-	✓

Fōmcore
SERVE. CREATE. INSPIRE.

1770 E. Keating Ave - Muskegon, MI 49442 • Tel: 231.366.4791 • www.fomcore.com

ADDITIONAL
RESOURCES



CLICK TO VIEW »