

SOCIAL SERIES

# CLUB SOCIAL CHAIR

Product No. F050

Create a welcoming environment for your next space. Featuring comfortable, functional, and creative seating options. The Full Social Chair is a keystone piece all on it's own or create an adaptable seating arrangement using multiple pieces from the Social series.



Shown with 6" Mod Legs

## DETAILS

### CONSTRUCTION

- Solid foam construction
- Wood base to fit foot options
- Reinforced seams and stitching
- Made in USA
- Backed with a lifetime warranty

### MODIFICATION

- Textile and placement
- Foot and finish options
- Stitching color
- Power options
- Embroidery

## QUICK COMBOS

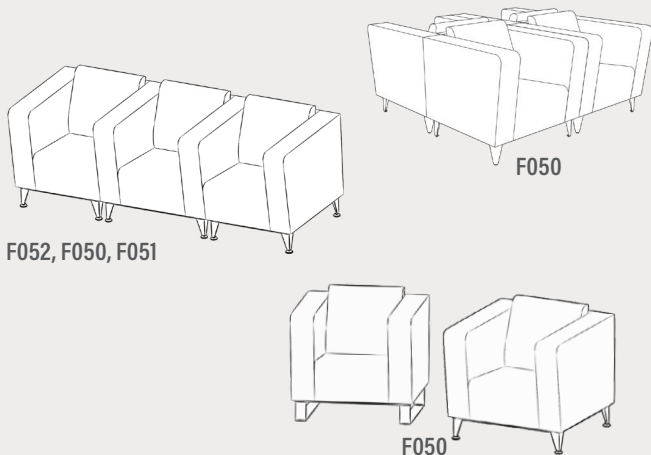

# HOW TO SPECIFY F050

## STEP 1: SEAT HEIGHT

DIMENSION (L x W x H)	SEAT HEIGHT
	18"

## STEP 2: FOOT

### 6" PREMIUM FOOT OPTIONS



Large Sled Leg (S29)  
Silver



Large Sled Leg (S29)  
Black



6" Mod Leg (M6)



6" Caster (C6)



6" Rectangle (R6)  
Black



6" Rectangle (R6)  
Silver



6" Triangle (T6)  
Black



6" Triangle (T6)  
Silver

\*Reference the product breakdown on back for availability.

## STEP 3: GRADE AND TEXTILE

### GRADES & SWATCHES



[CLICK TO VIEW »](#)

### FABRIC DIRECTION & COLOR GUIDE



[CLICK TO VIEW »](#)

### COLOR GUIDE

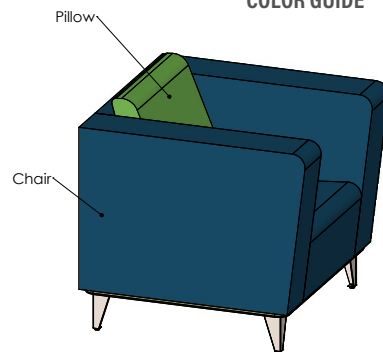

\*Thread will default to match the seat textile.

## STEP 4: MODIFICATIONS (OPTIONAL)

### INTEGRATED POWER OPTIONS\* (PI, PI+)



White



Silver

PI = 1 Power Unit

PI+ = 2 Power Units

### EMBROIDERY

- Personalize your furniture with embroidery!
- We can embroider up to 12" x 15" artwork

### EMBROIDERY SPECS

[CLICK TO VIEW »](#)



### FLAME RETARDANT

- CAL TB-133 - Optional flame retardant add on.

\*Reference the product breakdown on back for availability.

## STEP 5: CONFIGURE PART NUMBER

### FILL IN YOUR PART NUMBER

F	0	5	0	-	3	5	x	3	6	x	3	2	-					-						
FAMILY					L				W				H				FOOT				POWER			
STEP 1												STEP 2				STEP 4* (OPTIONAL)								

### EXAMPLE PART NUMBER

F	0	5	0	-	3	5	x	3	6	x	3	2	-	R	6	-	P	1		
FAMILY					L				W				H				FOOT		POWER	

## STEP 6: CONFIGURE DESCRIPTION

### FILL IN YOUR DESCRIPTION

#### 1. CHAIR

1. Chair					
LOCATION	GRADE	MANUFACTURER	PATTERN	COLOR	

#### 2. PILLOW

2. Pillow					
LOCATION	GRADE	MANUFACTURER	PATTERN	COLOR	

#### FOOT

NAME/COLOR
------------

#### POWER\*

COLOR	QUANTITY
-------	----------

#### EMBROIDERY\*

LOCATION	NAME
----------	------

#### FLAME RETARDANT\*

--

STEP 3

### EXAMPLE DESCRIPTION

#### 1. CHAIR

1. Chair	1	Spradling	Silvertex	Sage
LOCATION	GRADE	MANUFACTURER	PATTERN	COLOR

#### 2. PILLOW

2. Pillow	3	Momentum	Tribeca	Fossil
LOCATION	GRADE	MANUFACTURER	PATTERN	COLOR

#### FOOT

6" Rectangle Leg - Black	White	1
NAME/COLOR	COLOR	QUANTITY

#### EMBROIDERY\*

Seat	Rocket Logo
LOCATION	NAME

#### FLAME RETARDANT\*

CAL TB-133
------------

\*Optional add-ons. Reference product breakdown for availability.

INCLUDE ON PURCHASE ORDER

### EXAMPLE CONFIGURATION

F050-35x36x32-R6-PI

1. Chair: Grade 1, Spradling, Silvertex, Sage | 2. Pillow: Grade 3, Momentum, Tribeca, Fossil

Foot: 6" Rectangle Leg Black | Power: White, Quantity: 1 | Embroidery: Seat, Rocket logo | CAL TB-133

### PRODUCT BREAKDOWN

## CLUB SOCIAL CHAIR (F050)

Product No.	Dimen./Weight (L x W x H)	FOOT OPTIONS											INTEGRATED POWER OPTION											HPL	Emb.
		Zip Z	Standard G1 L1		3" Premium R3 C3		6" Premium S16 S29 C6 T6 R6 M6					Standard G1 L1		3" Premium R3 C3		6" Premium S16 S29 C6 T6 R6 M6									
F050-35x36x32	35" x 36" x 32" 44 lbs. (18" Seat Height)	-	-	-	-	-	-	✓	✓	✓	✓	✓	-	-	-	-	-	✓	✓	✓	✓	✓	-	✓	

**Fōmcore**  
SERVE. CREATE. INSPIRE.

1770 E. Keating Ave - Muskegon, MI 49442 • Tel: 231.366.4791 • [www.fomcore.com](http://www.fomcore.com)

ADDITIONAL  
RESOURCES



CLICK TO VIEW »