

## STEP SERIES

# TWO STEP CURVED INSIDE CORNER

Product No. F087

The Two Step Curved Inside Corner is designed with a smoothly curved back, making it ideal for fluid, collaborative seating arrangements. Whether used alone or as part of a larger configuration, this piece offers versatile seating options that inspire creativity. The flat steps provide stable support, while the curved back adds a dynamic, modern touch. When combined with other pieces from our Step Series, this is the perfect addition to student-centered spaces like commons areas, media centers, the spaces in between, and more.

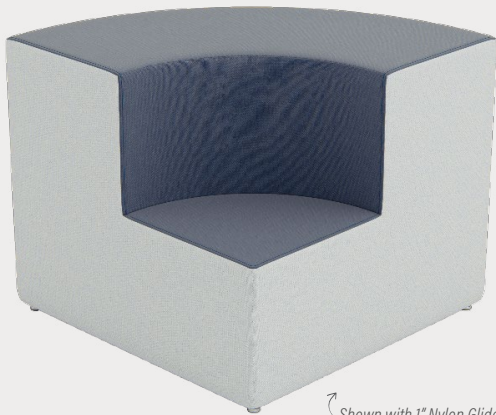

## DETAILS

### CONSTRUCTION

- Solid foam construction
- Wood base to fit foot options
- Reinforced seams and stitching
- Made in USA
- Backed with a lifetime warranty

### MODIFICATION

- Textile and placement
- Foot and Finish options
- Stitching color
- Embroidery

## QUICK COMBOS

IDEA STARTERS COMING SOON

# HOW TO SPECIFY F087

## STEP 1: HEIGHT

DIMENSION (L x W)	HEIGHT	STEP HEIGHT
	32"	16.5"

## STEP 2: FOOT

### 1" STANDARD FOOT OPTIONS

- Nylon Glide (G1)
- Felt Glide (G1)
- 

*\*Reference the product breakdown on back for availability.*

## STEP 3: GRADE AND TEXTILE

### GRADES & SWATCHES



[CLICK TO VIEW »](#)

### FABRIC DIRECTON & COLOR GUIDE



[CLICK TO VIEW »](#)

### COLOR GUIDE

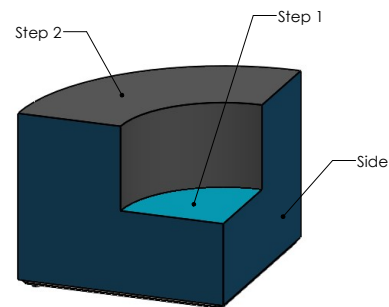

*\*Thread will default to match the seat textile.*

## STEP 4: MODIFICATIONS (OPTIONAL)

### EMBROIDERY

- Personalize your furniture with embroidery!
- We can embroider up to 12" x 15" artwork

### FLAME RETARDANT

- CAL TB-133
- Optional flame retardant add on.

### EMBROIDERY SPECS

[CLICK TO VIEW »](#)



*\*Reference the product breakdown on back for availability.*

## STEP 5: CONFIGURE PART NUMBER

### FILL IN YOUR PART NUMBER

F	0	8	7	-	3	8	x	3	8	x	3	2	-					
FAMILY					STEP 1								STEP 2					
LOCATION					GRADE				MANUFACTURER				PATTERN			COLOR		

### EXAMPLE PART NUMBER

F	0	8	7	-	3	8	x	3	8	x	3	2	-	G	1			
FAMILY					STEP 1								STEP 2					
LOCATION					GRADE				MANUFACTURER				PATTERN			COLOR		

## STEP 6: CONFIGURE DESCRIPTION

### FILL IN YOUR DESCRIPTION

#### 1. SIDES

1. Sides					
LOCATION	GRADE	MANUFACTURER	PATTERN	COLOR	

#### 2. BACK

2. Back					
LOCATION	GRADE	MANUFACTURER	PATTERN	COLOR	

#### 3. STEP-1

3. Step 1					
LOCATION	GRADE	MANUFACTURER	PATTERN	COLOR	

#### 4. STEP-2

4. Step 2					
LOCATION	GRADE	MANUFACTURER	PATTERN	COLOR	

STEP 3

#### FOOT

1" Nylon Glide
NAME/COLOR

#### EMBROIDERY\*

Seat	Rocket Logo
LOCATION	NAME

#### FIRE RETARDANCY\*

CAL TB-133
------------

### EXAMPLE DESCRIPTION

#### 1. SIDES

1. Sides	1	Spradling	Silvertex	Sage
LOCATION	GRADE	MANUFACTURER	PATTERN	COLOR

#### 2. BACK

2. Back	3	Momentum	Tribeca	Fossil
LOCATION	GRADE	MANUFACTURER	PATTERN	COLOR

#### 3. STEP-1

3. Step 1	3	Momentum	Tribeca	Fossil
LOCATION	GRADE	MANUFACTURER	PATTERN	COLOR

#### 4. STEP-2

4. Step 2	3	Momentum	Tribeca	Fossil
LOCATION	GRADE	MANUFACTURER	PATTERN	COLOR

#### FOOT

1" Nylon Glide
NAME/COLOR

#### EMBROIDERY\*

Seat	Rocket Logo
LOCATION	NAME

#### FIRE RETARDANCY\*

CAL TB-133
------------

\*Optional add-ons. Reference product breakdown for availability.

INCLUDE ON PURCHASE ORDER

## EXAMPLE CONFIGURATION

F087-38x38x32-G1

1. Sides: Grade 1, Spradling, Silvertex, Sage | 2. Back: Grade 3, Momentum, Tribeca, Fossil |  
 3. Step-1: Grade 3, Momentum, Tribeca, Fossil | 4. Step-2: Grade 3, Momentum, Tribeca, Fossil |  
 Foot: 1" Nylon Glide | Embroidery: Seat, Rocket logo | CAL TB-133

## PRODUCT BREAKDOWN

### TWO STEP CURVED INSIDE CORNER (F087)

Product No.	Dimen./Weight (L x W x H)	FOOT AND FINISH OPTIONS												INTEGRATED POWER OPTIONS						HPL	Emb.				
		Zip Z	Standard		3" Premium		6" Premium						Standard		3" Premium		6" Premium								
			G1	L1	R3	C3	S16	S29	C6	T6	R6	M6	G1	L1	R3	C3	S16	S29	C6			T6	R6	M6	
F087-38x38x32	38" x 38" x 32" 50 lbs.	-	✓	✓	-	-	-	-	-	-	-	-	-	-	-	-	-	-	-	-	-	-	-	-	✓



1770 E. Keating Ave - Muskegon, MI 49442 • Tel: 231.366.4791 • [www.fomcore.com](http://www.fomcore.com)

ADDITIONAL RESOURCES



CLICK TO VIEW »