

NEST SERIES

FALCON'S NEST

Product No. F086

Our patent pending Nest Series* is where mindfulness and reflection meet. The Falcon's Nest* is the perfect spot for a little alone time. Learners can tuck away in this sound dampening space to find a comfortable and safe space to sit, read and reflect. The solid foam construction allows for light-weight and easy movement.



DETAILS

CONSTRUCTION

- Solid foam construction
- Reinforced seams and stitching
- Fully zippered (no wood base)
- Patented design*
- Made in USA
- Backed with a lifetime warranty

MODIFICATION

- Textile and placement
- Colored stitching
- Embroidery

QUICK COMBOS

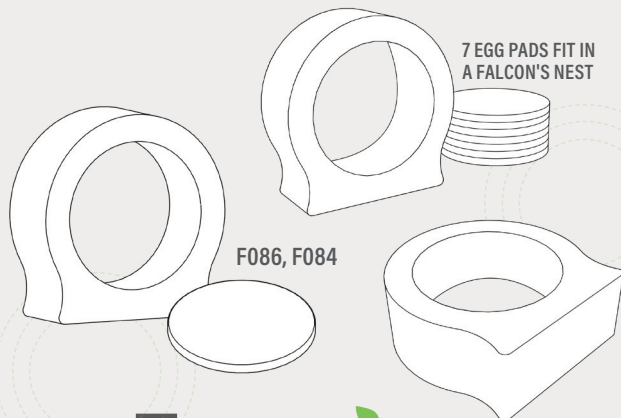

Fōmcore
SERVE. CREATE. INSPIRE.

HOW TO SPECIFY F086

STEP 1: HEIGHT

DIMENSIONS (L x W x H)



64" x 24" x 65"

STEP 2: FULLY ZIPPERED

FULLY ZIPPERED



Fully Zippered (Z)

**Reference the product breakdown on back for availability.*

STEP 3: GRADE AND TEXTILE

GRADES & SWATCHES



[CLICK TO VIEW »](#)

FABRIC DIRECTION & COLOR GUIDE



[CLICK TO VIEW »](#)

COLOR GUIDE

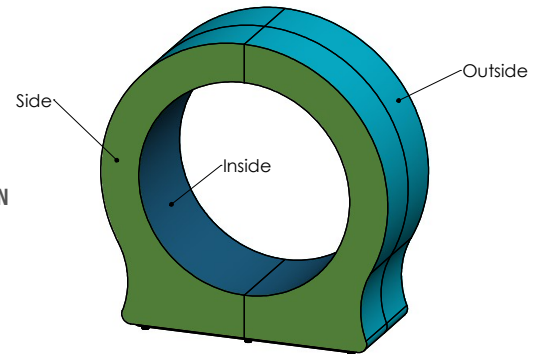

**Thread will default to match the seat textile.*

**Thread will default to match the seat textile.*

STEP 4: MODIFICATIONS (OPTIONAL)

EMBROIDERY

- Personalize your furniture with embroidery!
- We can embroider up to 12" x 15" artwork

EMBROIDERY SPECS

[CLICK TO VIEW »](#)



FLAME RETARDANT

- CAL TB-133
- Optional flame retardant add on.

**Reference the product breakdown on back for availability.*

STEP 5: CONFIGURE PART NUMBER

FILL IN YOUR PART NUMBER

F	0	8	6	-	6	4	x	2	4	x	6	5	-	Z		
FAMILY					STEP 1								STEP 2			
L					W				H				ZIP			

EXAMPLE PART NUMBER

F	0	8	6	-	6	4	x	2	4	x	6	5	-	Z		
FAMILY					STEP 1								STEP 2			
L					W				H				ZIP			

STEP 6: CONFIGURE DESCRIPTION

FILL IN YOUR DESCRIPTION

1. INSIDE

1. Inside				
LOCATION	GRADE	MANUFACTURER	PATTERN	COLOR

2. SIDES

2. Sides				
LOCATION	GRADE	MANUFACTURER	PATTERN	COLOR

3. OUTSIDE

3. Outside				
LOCATION	GRADE	MANUFACTURER	PATTERN	COLOR

EMBROIDERY*

Seat	
LOCATION	NAME

FIRE RETARDANCY*

CAL TB-133

STEP 3

EXAMPLE DESCRIPTION

1. INSIDE

1. Inside	1	Spradling	Silvertex	Sage
LOCATION	GRADE	MANUFACTURER	PATTERN	COLOR

2. SIDES

2. Sides	3	Momentum	Tribeca	Fossil
LOCATION	GRADE	MANUFACTURER	PATTERN	COLOR

3. OUTSIDE

3. Outside	3	Momentum	Tribeca	Fossil
LOCATION	GRADE	MANUFACTURER	PATTERN	COLOR

EMBROIDERY*

Seat	Rocket Logo
LOCATION	NAME

FIRE RETARDANCY*

CAL TB-133

*Optional add-ons. Reference product breakdown for availability.

INCLUDE ON PURCHASE ORDER

EXAMPLE CONFIGURATION

F086-64x24x65-Z

1. Inside: Grade 1, Spradling, Silvertex, Sage | 2. Sides: Grade 3, Momentum, Tribeca, Fossil
3. Outside: Grade 3, Momentum, Tribeca, Fossil | Embroidery: Seat, Rocket logo | CAL TB-133

PRODUCT BREAKDOWN

FALCON'S NEST (F086)

Product No.	Dimen./Weight (L x W x H)	FOOT OPTIONS												INTEGRATED POWER OPTION						HPL	Emb.					
		Zip	Standard		3" Premium		6" Premium				Standard		3" Premium		6" Premium											
			Z	G1	L1	R3	C3	S16	S29	C6	T6	R6	M6	G1	L1	R3	C3	S16	S29			C6	T6	R6	M6	
F086-64x24x65	64" x 24" x 65" 49 lbs.	✓	-	-	-	-	-	-	-	-	-	-	-	-	-	-	-	-	-	-	-	-	-	-	-	✓

Fōmcore
SERVE. CREATE. INSPIRE.

1770 E. Keating Ave - Muskegon, MI 49442 • Tel: 231.366.4791 • www.fomcore.com

ADDITIONAL
RESOURCES



CLICK TO VIEW »