

SOCIAL SERIES

ARMLESS SOCIAL CHAIR

Product No. F053

Create the space you are looking for using the Social Series. The Armless Social Chair can be used on it's own or connect it with multiple pieces from the series to fit your exact environment needs.



DETAILS

CONSTRUCTION

- Solid foam construction
- Wood base to fit foot options
- Reinforced seams and stitching
- Made in USA
- Backed with a lifetime warranty

MODIFICATION

- Textile and placement
- Foot and finish options
- Stitching color
- Power options
- Embroidery

QUICK COMBOS

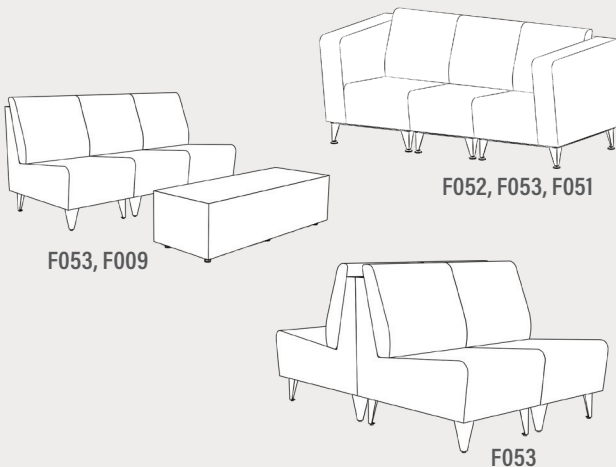

HOW TO SPECIFY F053

STEP 1: SEAT HEIGHT

DIMENSION (L x W x H)	SEAT HEIGHT
 21.5" x 36" x 32"	18"

STEP 2: FOOT

6" PREMIUM FOOT OPTIONS

-  Large Sled Leg (S29)
Silver
-  Large Sled Leg (S29)
Black
- 6" Mod Leg (M6)

- 6" Rectangle (R6)
Black
- 6" Rectangle (R6)
Silver
- 6" Triangle (T6)
Black
- 6" Triangle (T6)
Silver
- 6" Caster (C6)

**Reference the product breakdown on back for availability.*

STEP 3: GRADE AND TEXTILE

GRADES & SWATCHES FABRIC DIRECTION & COLOR GUIDE

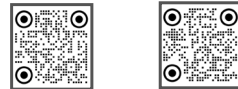

[CLICK TO VIEW »](#)

[CLICK TO VIEW »](#)

COLOR GUIDE

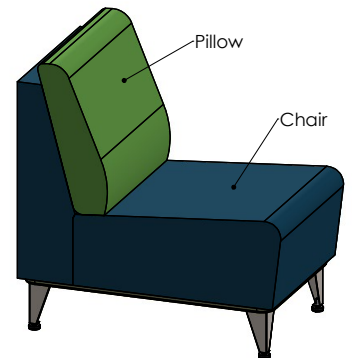

**Thread will default to match the seat textile.*

STEP 4: MODIFICATIONS (OPTIONAL)

INTEGRATED POWER OPTIONS* (PI, PI+)

-  White
-  Silver

PI = 1 Power Unit
PI+ = 2 Power Units

EMBROIDERY

- Personalize your furniture with embroidery!
- We can embroider up to 12" x 15" artwork

EMBROIDERY SPECS

[CLICK TO VIEW »](#)



FLAME RETARDANT

- CAL TB-133
- Optional flame retardant add on.

**Reference the product breakdown on back for availability.*

STEP 5: CONFIGURE PART NUMBER

FILL IN YOUR PART NUMBER

F	0	5	3	-	2	1	.5	x	3	6	x	3	2	-	R	6	-					
FAMILY					L					W					H		FOOT		POWER			
STEP 1													STEP 2		STEP 4* (OPTIONAL)							

EXAMPLE PART NUMBER

F	0	5	3	-	2	1	.5	x	3	6	x	3	2	-	R	6	-	P	I			
FAMILY					L					W					H		FOOT		POWER			

STEP 6: CONFIGURE DESCRIPTION

FILL IN YOUR DESCRIPTION

1. CHAIR

1. Chair					
LOCATION	GRADE	MANUFACTURER	PATTERN	COLOR	

2. PILLOW

2. Pillow					
LOCATION	GRADE	MANUFACTURER	PATTERN	COLOR	

FOOT

NAME/COLOR

POWER*

COLOR	QUANTITY
-------	----------

EMBROIDERY*

LOCATION	NAME
----------	------

FLAME RETARDANT*

--

STEP 3

EXAMPLE DESCRIPTION

1. CHAIR

1. Chair	1	Spradling	Silvertex	Sage
LOCATION	GRADE	MANUFACTURER	PATTERN	COLOR

2. PILLOW

2. Pillow	3	Momentum	Tribeca	Fossil
LOCATION	GRADE	MANUFACTURER	PATTERN	COLOR

FOOT

6" Rectangle Leg - Black	White	1
NAME/COLOR	COLOR	QUANTITY

EMBROIDERY*

Seat	Rocket Logo
LOCATION	NAME

FLAME RETARDANT*

CAL TB-133

*Optional add-ons. Reference product breakdown for availability.

INCLUDE ON PURCHASE ORDER

EXAMPLE CONFIGURATION

F053-21.5x36x32-R6-PI

1. Chair: Grade 1, Spradling, Silvertex, Sage | 2. Pillow: Grade 3, Momentum, Tribeca, Fossil

Foot: 6" Rectangle Leg Black | Power: White, Quantity: 1 | Embroidery: Seat, Rocket logo | CAL TB-133

PRODUCT BREAKDOWN

ARMLESS SOCIAL CHAIR (F053)

Product No.	Dimen./Weight (L x W x H)	FOOT OPTIONS												INTEGRATED POWER OPTION								HPL	Emb.	
		Zip		Standard		3" Premium		6" Premium				Standard		3" Premium		6" Premium								
		Z	G1	L1	R3	C3	S16	S29	C6	T6	R6	M6	G1	L1	R3	C3	S16	S29	C6	T6	R6			M6
F053-21.5x36x32	21.5" x 36" x 32" 24 lbs. (18" Seat Height)	-	-	-	-	-	-	✓	✓	✓	✓	✓	-	-	-	-	-	✓	✓	✓	✓	✓	-	✓



1770 E. Keating Ave - Muskegon, MI 49442 • Tel: 231.366.4791 • www.fomcore.com

ADDITIONAL RESOURCES



[CLICK TO VIEW »](#)