

NETWORK SERIES

BOOMERANG BENCH 2.0

Product No. F045

With our light-weight, solid foam construction, you can maneuver the Boomerang Bench 2.0 into endless combinations. Meetings, gatherings, and even quick chats will flourish in your purposefully curated spaces. Showcasing the variety of geometry from the Boomerang Bench 2.0, your creativity has no bounds to craft the proper environment for any situation.



DETAILS

CONSTRUCTION

- Solid foam construction
- Wood base to fit foot options
- Reinforced seams and stitching
- Made in USA
- Backed with a lifetime warranty

MODIFICATION

- Textile and placement
- Foot and finish options
- Stitching color
- Power options
- Embroidery

QUICK COMBOS

IDEA STARTERS COMING SOON



HOW TO SPECIFY F045

STEP 1: SEAT HEIGHT

DIMENSION (L x W)	SEAT HEIGHT
 68" x 18"	16"
	18"

STEP 2: FOOT

1" STANDARD FOOT OPTIONS

-  Nylon Glide (G1)
-  Felt Glide (G1)
-
-

6" PREMIUM FOOT OPTIONS

-
-

**Reference the product breakdown on back for availability.*

STEP 3: GRADE AND TEXTILE

GRADES & SWATCHES



[CLICK TO VIEW »](#)

FABRIC DIRECTION & COLOR GUIDE



[CLICK TO VIEW »](#)

COLOR GUIDE

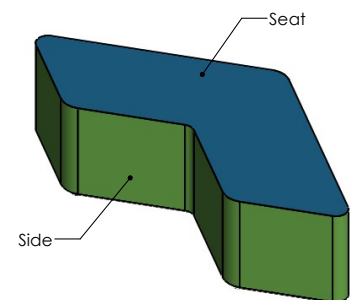

**Thread will default to match the seat textile.*

STEP 4: MODIFICATIONS (OPTIONAL)

INTEGRATED POWER OPTIONS* (PI, PI+)

- White
 - Silver
- PI = 1 Power Unit
PI+ = 2 Power Units

EMBROIDERY

- Personalize your furniture with embroidery!
- We can embroider up to 12" x 15" artwork.

EMBROIDERY SPECS

[CLICK TO VIEW »](#)



FLAME RETARDANT

- CAL TB-133
- Optional flame retardant add on.

**Reference the product breakdown on back for availability.*



STEP 5: CONFIGURE PART NUMBER

FILL IN YOUR PART NUMBER

F	0	4	5	-	x	x	-			-		
FAMILY					STEP 1			FOOT			POWER	
											STEP 4* (OPTIONAL)	

EXAMPLE PART NUMBER

F	0	4	5	-	6	8	x	1	8	x	1	8	-	M	6	-	P	1
FAMILY					L		W		H		FOOT			POWER				

STEP 6: CONFIGURE DESCRIPTION

FILL IN YOUR DESCRIPTION

1. SEAT

1. Seat				
LOCATION	GRADE	MANUFACTURER	PATTERN	COLOR

2. SIDE

2. Side				
LOCATION	GRADE	MANUFACTURER	PATTERN	COLOR

FOOT

NAME/COLOR

POWER*

COLOR	QUANTITY
-------	----------

EMBROIDERY*

LOCATION	NAME
----------	------

FIRE RETARDANCY*

--

EXAMPLE DESCRIPTION

1. SEAT

1. Seat	1	Spradling	Silvertex	Sage
LOCATION	GRADE	MANUFACTURER	PATTERN	COLOR

2. SIDE

2. Side	3	Momentum	Tribeca	Fossil
LOCATION	GRADE	MANUFACTURER	PATTERN	COLOR

FOOT

6" Mod Leg

POWER*

White	1
COLOR	QUANTITY

EMBROIDERY*

Seat	Rocket Logo
LOCATION	NAME

FIRE RETARDANCY*

CAL TB-133

*Optional add-ons. Reference product breakdown for availability.

INCLUDE ON PURCHASE ORDER

EXAMPLE CONFIGURATION

F045-68x18x18-M6-PI

1. Seat: Grade 1, Spradling, Silvertex, Sage | 2. Side: Grade 3, Momentum, Tribeca, Fossil

Foot: 6" Mod Leg | Power: White, Quantity: 1 | Embroidery: Seat, Rocket Logo | CAL TB-133

PRODUCT BREAKDOWN

BOOMERANG BENCH 2.0 (F045)

Product No.	Dimen./Weight (L x W x H)	FOOT AND FINISH OPTIONS											INTEGRATED POWER OPTIONS								HPL	Emb.		
		Zip Z	Standard		3" Premium		6" Premium						Standard		3" Premium		6" Premium							
			G1	L1	R3	C3	S16	S29	C6	T6	R6	M6	G1	L1	R3	C3	S16	S29	C6	T6			R6	M6
F045-68x18x16	68" x 18" x 16" 31.5 lbs.	-	✓	✓	-	✓	-	-	✓	-	-	✓	✓	✓	-	✓	-	-	-	-	-	-	-	✓
F045-68x18x18	68" x 18" x 18" 33 lbs.	-	✓	✓	-	✓	-	-	✓	-	-	✓	✓	✓	-	✓	-	-	✓	-	-	✓	-	✓



1770 E. Keating Ave - Muskegon, MI 49442 • Tel: 231.366.4791 • www.fomcore.com

ADDITIONAL RESOURCES



CLICK TO VIEW »