

STEP SERIES

THREE STEP INSIDE CORNER

Product No. F035

Since the Three Step Inside Corner is made of solid foam, it's light and convenient to move around and no hard edges. With the Step line you can fit them together for collaboration, tiered seating, or even small groups by simply shifting them around.

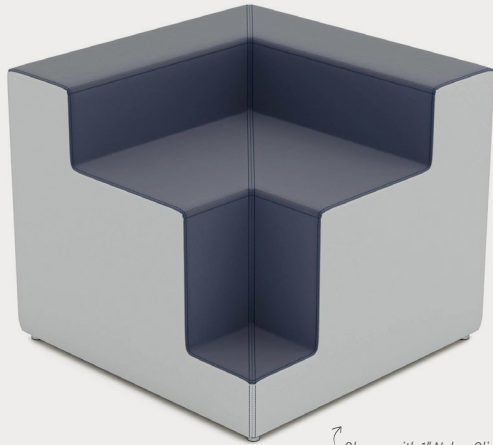

Shown with 1" Nylon Glides

DETAILS

CONSTRUCTION

- Solid foam construction
- Wood base to fit foot options
- Reinforced seams and stitching
- Made in USA
- Backed with a lifetime warranty

MODIFICATION

- Seat height
- Textile and placement
- Foot and finish options
- Stitching colors
- Embroidery
- Power options

QUICK COMBOS

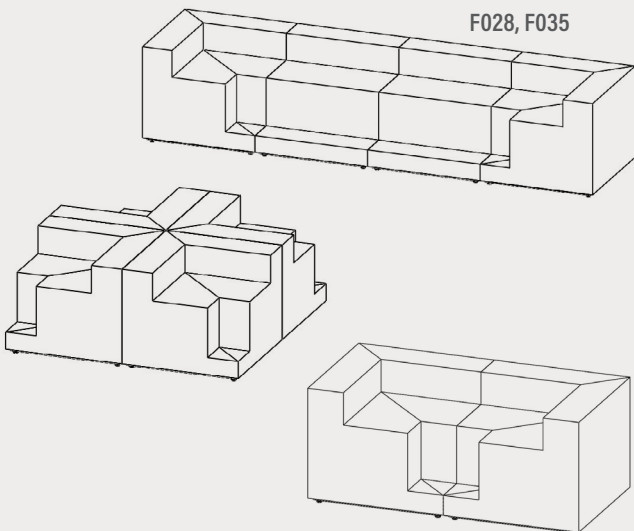

HOW TO SPECIFY F035

STEP 1: SEAT HEIGHT

DIMENSION (L x W)	HEIGHT	STEP 1 HEIGHT	STEP 2 HEIGHT
38" x 38"	32"	7"	23"

STEP 2: FOOT

1" STANDARD FOOT OPTIONS

- Nylon Glide (G1)
- Felt Glide (G1)
- 1" Low Profile Leg (L1)
Black

**Reference the product breakdown on back for availability.*

STEP 3: GRADE AND TEXTILE

GRADES & SWATCHES



[CLICK TO VIEW »](#)

FABRIC DIRECTON & COLOR GUIDE



[CLICK TO VIEW »](#)

COLOR GUIDE

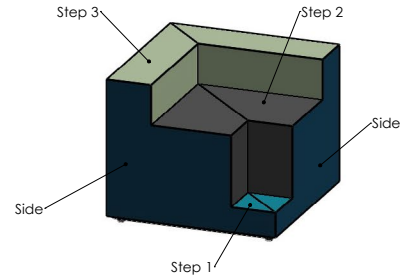

**Thread will default to match the seat textile.*

STEP 4: MODIFICATIONS (OPTIONAL)

INTEGRATED POWER OPTIONS* (PI, PI+)

- White
- Silver
- PI = 1 Power Unit
- PI+ = 2 Power Units

EMBROIDERY

- Personalize your furniture with embroidery!
- We can embroider up to 12" x 15" artwork

EMBROIDERY SPECS

[CLICK TO VIEW »](#)



FLAME RETARDANT

- CAL TB-133
- Optional flame retardant add on.

**Reference the product breakdown on back for availability.*



STEP 5: CONFIGURE PART NUMBER

FILL IN YOUR PART NUMBER

F	0	3	5	-	3	8	x	3	8	x	3	2	-				-					
FAMILY					L				W				H				FOOT			POWER		
STEP 1												STEP 2			STEP 4* (OPTIONAL)							

EXAMPLE PART NUMBER

F	0	3	5	-	3	8	x	3	8	x	3	2	-	L	1	-	P	1		
FAMILY					L				W				H				FOOT		POWER	

STEP 6: CONFIGURE DESCRIPTION

FILL IN YOUR DESCRIPTION

1. BACK

1. Back				
LOCATION	GRADE	MANUFACTURER	PATTERN	COLOR

2. SIDE

2. Side				
LOCATION	GRADE	MANUFACTURER	PATTERN	COLOR

3. STEP 1

3. Step 1				
LOCATION	GRADE	MANUFACTURER	PATTERN	COLOR

4. STEP 2

4. Step 2				
LOCATION	GRADE	MANUFACTURER	PATTERN	COLOR

5. STEP 3

5. Step 3				
LOCATION	GRADE	MANUFACTURER	PATTERN	COLOR

STEP 3

FOOT

NAME/COLOR

POWER*

COLOR	QUANTITY
-------	----------

EMBROIDERY*

LOCATION	NAME
----------	------

FLAME RETARDANT*

--

EXAMPLE DESCRIPTION

1. BACK

1. Seat	1	Spradling	Silvertex	Sage
LOCATION	GRADE	MANUFACTURER	PATTERN	COLOR

2. SIDE

2. Side	3	Momentum	Tribeca	Fossil
LOCATION	GRADE	MANUFACTURER	PATTERN	COLOR

3. STEP 1

3. Step 1	1	Spradling	Silvertex	Sage
LOCATION	GRADE	MANUFACTURER	PATTERN	COLOR

4. STEP 2

4. Step 2	3	Momentum	Tribeca	Fossil
LOCATION	GRADE	MANUFACTURER	PATTERN	COLOR

5. STEP 3

5. Step 3	3	Momentum	Tribeca	Fossil
LOCATION	GRADE	MANUFACTURER	PATTERN	COLOR

FOOT

6" Rectangle Leg - Black
NAME/COLOR

POWER*

White	1
COLOR	QUANTITY

EMBROIDERY*

Seat	Rocket Logo
LOCATION	NAME

FLAME RETARDANT*

CAL TB-133

*Optional add-ons. Reference product breakdown for availability.

INCLUDE ON PURCHASE ORDER

EXAMPLE CONFIGURATION

F035-38x38x32-L1-PI

1. Back: Grade 1, Spradling, Silvertex, Sage | 2. Side: Grade 3, Momentum, Tribeca, Fossil | 3. Step 1: Grade 1, Spradling, Silvertex, Sage | 4. Step 2: Grade 3, Momentum, Tribeca, Fossil | 5. Step 3: Grade 3, Momentum, Tribeca, Fossil

Foot: 1" Low Profile Black Leg | Power: White, Quantity: 1 | Embroidery: Seat, Rocket logo | CAL TB-133

PRODUCT BREAKDOWN

THREE STEP INSIDE CORNER (F035)

Product No.	Dimen./Weight (L x W x H)	Zip Z	FOOT OPTIONS										INTEGRATED POWER OPTION						HPL	Emb.					
			Standard		3" Premium		6" Premium						Standard		6" Premium										
			G1	L1	R3	C3	S16	S29	C6	T6	R6	M6	G1	L1	R3	C3	S16	S29	C6	T6	R6	M6			
F035-38x38x32	38" x 38" x 32" 46.5 lbs.	-	✓	✓	-	-	-	-	-	-	-	-	✓	✓	-	-	-	-	-	-	-	-	-	-	✓



ADDITIONAL RESOURCES



CLICK TO VIEW »