

STEP SERIES TWO STEP

Product No. F027

This finely crafted foam step is built to impress. Since the Two Step is made of solid foam, it's light and convenient to move around and NO HARD EDGES, making it safe for learners of any age. With the entire STEP line you can fit them together for collaboration, tiered seating, or even small groups by simply shifting them around. The Step Series is a wonderful seating solution in transition spaces like, hallways and entry areas. Create a unique seating space in the center of a room or push them against a wall in any combination.



Shown with 1" Nylon Glides

DETAILS

CONSTRUCTION

- Solid foam construction
- Wood base to fit foot options
- Reinforced seams and stitching
- Made in USA
- Backed with a lifetime warranty

MODIFICATION

- Textile and placement
- Foot and Finish options
- Stitching color
- Power options
- Embroidery

QUICK COMBOS

F027, F030, F029

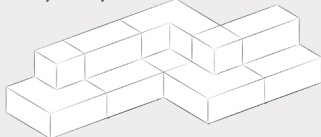

F027

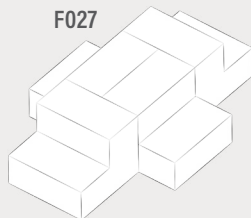

F027, F028

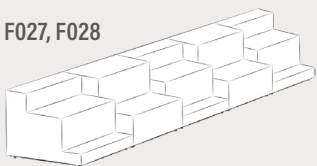

F027, F029

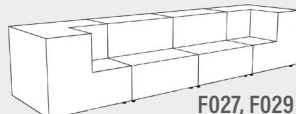

HOW TO SPECIFY F027

STEP 1: HEIGHT

DIMENSION (L x W)	HEIGHT	STEP HEIGHT
	32"	16.5"

STEP 2: FOOT

1" STANDARD FOOT OPTIONS

- Nylon Glide (G1)
- Felt Glide (G1)
- 1" Low Profile Leg (L1)
Black

*Reference the product breakdown on back for availability.

STEP 3: GRADE AND TEXTILE

GRADES & SWATCHES



[CLICK TO VIEW »](#)

FABRIC DIRECTON & COLOR GUIDE



[CLICK TO VIEW »](#)

COLOR GUIDE

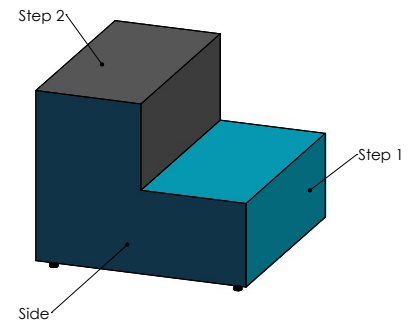

*Thread will default to match the seat textile.

STEP 4: MODIFICATIONS (OPTIONAL)

INTEGRATED POWER OPTIONS* (PI, PI+)

- White
- Silver

PI = 1 Power Unit
PI+ = 2 Power Units

EMBROIDERY

- Personalize your furniture with embroidery!
- We can embroider up to 12" x 15" artwork

EMBROIDERY SPECS

[CLICK TO VIEW »](#)



FLAME RETARDANT

- CAL TB-133
- Optional flame retardant add on.

*Reference the product breakdown on back for availability.

STEP 5: CONFIGURE PART NUMBER

FILL IN YOUR PART NUMBER

F	0	2	7	-	3	8	x	3	8	x	3	2	-					-						
FAMILY					L				W				H				FOOT				POWER			
STEP 1												STEP 2				STEP 3* (OPTIONAL)								

EXAMPLE PART NUMBER

F	0	2	7	-	3	8	x	3	8	x	3	2	-	G	1	-	P	I		
FAMILY					L				W				H				FOOT		POWER	

STEP 6: CONFIGURE DESCRIPTION

FILL IN YOUR DESCRIPTION

1. SIDE

1. Side					
LOCATION	GRADE	MANUFACTURER	PATTERN	COLOR	

2. BACK

2. Back					
LOCATION	GRADE	MANUFACTURER	PATTERN	COLOR	

3. STEP-1

3. Step 1					
LOCATION	GRADE	MANUFACTURER	PATTERN	COLOR	

4. STEP-2

4. Step 2					
LOCATION	GRADE	MANUFACTURER	PATTERN	COLOR	

FOOT

1" Nylon Glide
NAME/COLOR

POWER*

White	1
COLOR	QUANTITY

EMBROIDERY*

Seat	Rocket Logo
LOCATION	NAME

FLAME RETARDANT*

CAL TB-133

STEP 3

EXAMPLE DESCRIPTION

1. SIDE

1. Side	1	Spradling	Silvertex	Sage
LOCATION	GRADE	MANUFACTURER	PATTERN	COLOR

2. BACK

2. Back	3	Momentum	Tribeca	Fossil
LOCATION	GRADE	MANUFACTURER	PATTERN	COLOR

3. STEP-1

3. Step 1	3	Momentum	Tribeca	Fossil
LOCATION	GRADE	MANUFACTURER	PATTERN	COLOR

4. STEP-2

4. Step 2	3	Momentum	Tribeca	Fossil
LOCATION	GRADE	MANUFACTURER	PATTERN	COLOR

FOOT

1" Nylon Glide	White	1
NAME/COLOR	COLOR	QUANTITY

EMBROIDERY*

Seat	Rocket Logo
LOCATION	NAME

FLAME RETARDANT*

CAL TB-133

*Optional add-ons. Reference product breakdown for availability.

INCLUDE ON PURCHASE ORDER

EXAMPLE CONFIGURATION

F027-38x38x32-G1-PI

1. Seat: Grade 1, Spradling, Silvertex, Sage | 2. Back: Grade 3, Momentum, Tribeca, Fossil
 3. Step -1: Grade 3, Momentum, Tribeca, Fossil | 4. Step-2: Grade 3, Momentum, Tribeca, Fossil | Foot: 1" Nylon Glide
 | Power: White, Quantity: 1 | Embroidery: Seat, Rocket logo

PRODUCT BREAKDOWN

TWO STEP (F027)

Product No.	Dimen./Weight (LxWxH)	FOOT OPTIONS												INTEGRATED POWER OPTION								HPL	Emb.	
		Zip Z	Standard G1 L1		3" Premium R3 C3		6" Premium S16 S29 C6 T6 R6 M6				Standard G1 L1		3" Premium R3 C3		6" Premium S16 S29 C6 T6 R6 M6									
F027-38x38x32	38" x 38" x 32" 52 lbs.	-	✓	✓	-	-	-	-	-	-	-	-	✓	✓	-	-	-	-	-	-	-	-	-	✓



1770 E. Keating Ave - Muskegon, MI 49442 • Tel: 231.366.4791 • www.fomcore.com

ADDITIONAL RESOURCES



CLICK TO VIEW »