

COMMIT TODAY,  
BENEFIT TOMORROW:  
OBLIGATE ESSER FUNDS  
BY SEPT 2024, SPEND  
UNTIL 2026!

Fōmcore  
SERVE. CREATE. INSPIRE.

# IT'S NOT TOO LATE!

Maximize ESSER funds and transform your school with flexible, student-centric soft-seating solutions before they expire **SEPTEMBER 30TH!**

DON'T MISS OUT ON MAKING  
THE MOST OF LAST-MINUTE  
**ESSER FUNDS!**

Imagine transforming your school spaces into vibrant, flexible, and engaging environments that support student learning, well-being, and community connections. Fōmcore soft-seating solutions are designed to do just that - and there's time to take advantage of ESSER funds before they expire!

## MAXIMIZE ESSER FUNDING

BY FOCUSING ON THESE 4 KEY AREAS:



### ENHANCE LEARNING ENVIRONMENTS

Create dynamic, flexible spaces that adapt to diverse instructional methods, counteract learning loss, and support student engagement.



### SUPPORT SOCIAL EMOTIONAL LEARNING

Provide calming, inclusive areas that cater to students' mental health and emotional well-being.



### PROMOTE HEALTH & SAFETY

Implement easy-to-clean, comfortable seating with no hard edges to ensure safe environments that support posture, decrease fatigue, and promote student focus and engagement.



### FOSTER CONNECTION & BELONGING

Develop welcoming spaces for not only students but for families and community activities, strengthening school - community engagement and relationships.

CONTACT US: [WWW.FOMCORE.COM](http://WWW.FOMCORE.COM)

# – INTERACTIVE LEARNING ZONE –

COMMIT TODAY,  
BENEFIT TOMORROW:  
OBLIGATE ESSER FUNDS  
BY SEPT 2024, SPEND  
UNTIL 2026!

## ESSER CRITERIA & BENEFIT

Addressing Learning Loss

## IMPACT

Enhances collaboration and personalized instruction, helping to close learning gaps

[CLICK HERE](#) to learn more about Closing the Achievement Gap in Schools.

## IDEA STARTERS

- 1 FK007: (10) Lily Pads  
FK007-CART2: Lily Cart
- 2 F006: Amoeba Bench  
F005-18: 18" Round Ottoman
- 3 F055: (5) Spin Wedge Ottomans  
F165: (2) Medium Rock'n Rollers  
F008: Bump Bench



## IDEA STARTERS

- 1 3' X 3' Space



- 2 8' X 8' Space

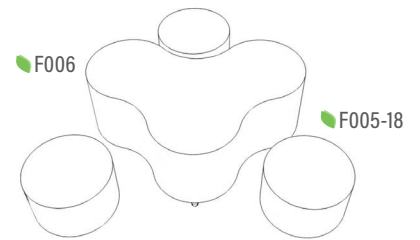

- 3 10' X 10' Space

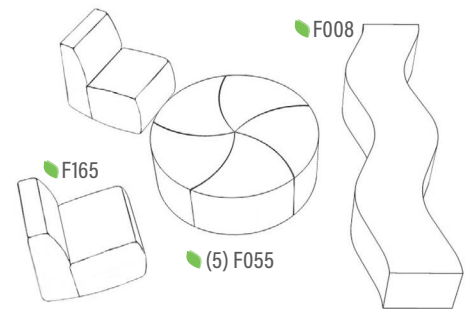

# – MINDFUL LEARNING CORNER –

## ESSER CRITERIA & BENEFIT

Supporting Social-Emotional Learning

## IMPACT

Provides a quiet area for mindfulness, reducing stress and enhancing focus

[CLICK HERE](#) to learn more about How SEL and Mindfulness Can Work Together.

## IDEA STARTERS

- 1 FF003: 3' FOM Bag
- 2 F536: Robin's Nest  
F960: Robin's Egg Pad
- 3 F029: Two Step Inside Corner  
F030: Two Step Outside Corner

- 1 4' X 4' Space

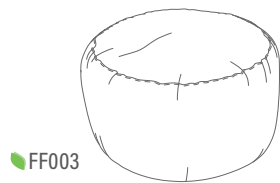

- 2 4' X 6' Space

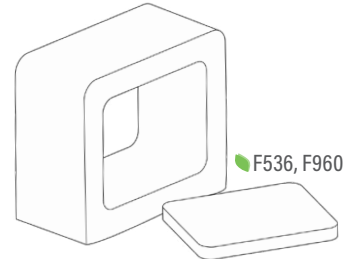

- 3 8' X 8' Space

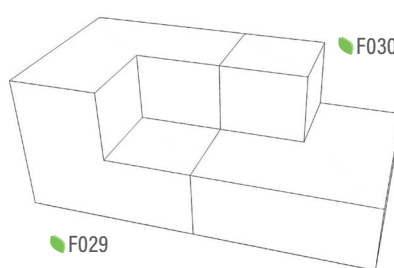

# — CALMING CORNER —

COMMIT TODAY,  
BENEFIT TOMORROW:  
OBLIGATE ESSER FUNDS  
BY SEPT 2024, SPEND  
UNTIL 2026!

## ESSER CRITERIA & BENEFIT

Promoting Health, Safety & Wellness

## IMPACT

Reduces sensory overload, providing a quiet, soothing environment

[CLICK HERE](#) to learn more about How to Implement Calming Corners in your Classroom.

## IDEA STARTERS

- 1 **FK034:** Hug Chair 2.0
- 2 **FK005:** Anderson Chair  
**FK501:** Log Ottoman
- 3 **FK033:** FÖM Desk  
**FK020:** FÖM Chair  
**FK028:** (2) FÖM Dividers

## IDEA STARTERS

### 1 2' X 4' Space



### 2 8' X 8' Space

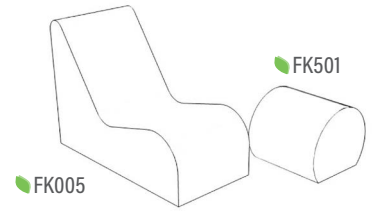

### 3 10' X 10' Space

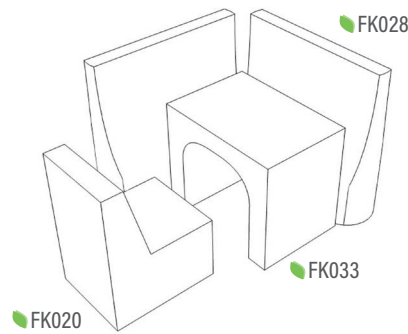

# — COLLABORATION STATIONS —

## ESSER CRITERIA & BENEFIT

Addressing Learning Loss

## IMPACT

Maximize space for group projects and peer tutoring

[CLICK HERE](#) to learn more about Strategies, Use Cases, & Techniques of Collaborative Learning.

## IDEA STARTERS

- 1 **F123:** Boomerang Sofa  
**F113:** (2) Boomerang Benches
- 2 **F016:** (4) Linear Chairs  
**F062:** (4) Linear Wedges
- 3 **F020:** (3) Curved Sofa Ins  
**F005-36:** 36" Round Ottoman  
**F121:** (2) Zero Gravity Chairs



## IDEA STARTERS

### 1 8' X 8' Space

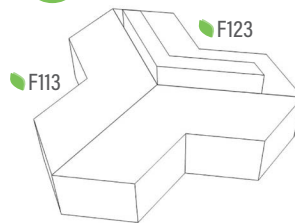

### 2 8' X 10' Space

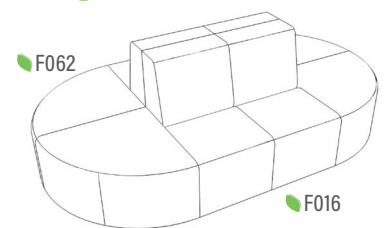

### 3 15' X 15' Space

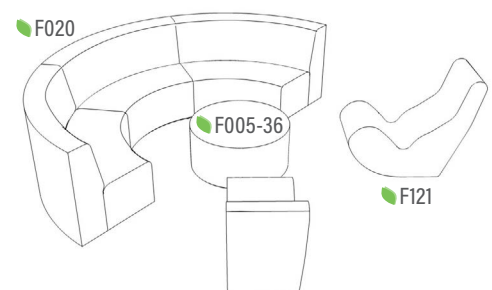

# UNDERSTANDING OBLIGATION & SPENDING DEADLINES FOR ESSER FUNDS

SHIPPED FREE IN 2024!



FOMCORE IS CURRENTLY OPERATING AT A 4-5 WEEK LEAD TIME!

## OBLIGATION DEADLINE:

# SEPTEMBER 30, 2024

all ESSER funds must be obligated

## SPENDING DEADLINE:

# JANUARY 25, 2025

(allowance until March 2026 with extension)

## OBLIGATION & SPENDING DEADLINES

**Obligation Deadline:** SEPTEMBER 30, 2024, all ESSER funds must be obligated. This means that schools and districts need to have committed these funds to specific expenditures through contracts, purchase orders, or similar means.

**Spending Period:** JANUARY 25, 2025 (allowance until MARCH 2026 with extension). Once the funds are obligated, schools and districts have an additional 14 months, with extension, to actually spend the money. This allows time for the completion of projects, delivery of goods, or execution of services.

## KEY TERMS

**Obligate:** This means funds must be committed to specific purposes by the specified deadline. Essentially, this involves making a formal commitment, such as signing contracts, issuing purchase orders, or creating legally binding agreements to spend the funds on specific items or services.

**Spending Period:** This is the timeframe within which the obligated funds must be actually spent or disbursed. This period extends beyond the obligation deadline to allow for the actual procurement, delivery, and implementation of goods and services.

CLICK HERE TO LEARN HOW TO UTILIZE  
ESSER FUNDING SPECIFIC TO YOUR STATE:  
[COVID-RELIEF-DATA.ED.GOV](https://www.covid-relief-data.ed.gov)

**Fōmcore**  
SERVE. CREATE. INSPIRE.

[www.fomcore.com](http://www.fomcore.com) · Tel: 231.366.4791

## STEPS TO FORMALLY OBLIGATE ESSER FUNDS FOR FURNITURE:

- 1 Needs Assessment and Planning**  
Assess specific furniture needs for classrooms and learning spaces, then create a detailed plan with required items, costs, and a timeline for procurement and installation.
- 2 Approval and Authorization**  
Present the plan to the school board for alignment with goals and secure necessary authorizations from school administration and finance departments.
- 3 Procurement Process**  
Issue RFPs to invite vendor bids, evaluate based on cost, quality, reputation, and ESSER compliance, then select the best vendor(s) for the school's needs.
- 4 Formal Agreements and Documentation**  
Sign detailed contracts with selected vendors, then issue purchase orders to confirm purchases and prices.
- 5 Reporting and Record-Keeping**  
Maintain copies of all contracts, purchase orders, and related documents. Record obligated funds in the financial management system and submit reports detailing fund usage.
- 6 Communication with Federal Authorities**  
Use federal or state grant management systems to report obligations and provide regular updates to the SEA and other relevant authorities, ensuring compliance with reporting requirements and deadlines.